

READ
THE ENQUIRER

EVERY
MORNING

AND GET
THE NEWS
WHILE IT
IS NEWS

IF YOU ARE NOT A SUBSCRIBER
PHONE YOUR ORDER TO

CANAL 2700

The
ENQUIRER
RADIO BOOK

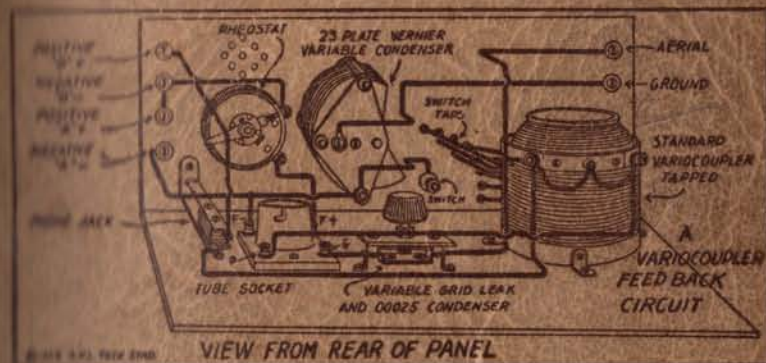

Containing Simple Fully Illustrated
Instructions on Building & Operating

The

Neutrodyne — Cockaday
Reinartz — Ultra Audion
Kopprasch — Woods
Reflex — Armstrong

And Many Other Long Distance
Receivers

The Enquirer - Cincinnati, Ohio

CONTENTS

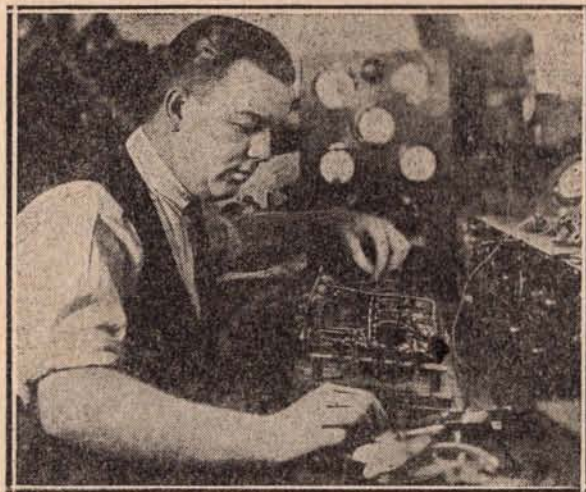

MR. BUTLER IN HIS LABORATORY

A WORD FROM THE AUTHOR

In this little book you will find practical, simple instructions showing how to build and operate some of the most efficient radio receivers so far developed.

During the last 5 years I have built and tested out in my laboratory hundreds of different hookups, and from these tests, know which circuits will bring in the distant stations with clarity and volume.

All of the receivers described are extremely efficient, and the picture diagrams show exactly how to arrange the parts. Simple understandable instructions are given which tell how to build and operate each set.

The chapters dealing with the selection of parts should be read over carefully, for they will show you how to tell good parts from poor ones. Buy good parts made by a responsible manufacturer, assemble them carefully, solder all connections, use a good aerial and ground, and any of the receivers described will give splendid results.

CARLTON E. BUTLER.

	Page
The Wonder of Radio.....	4
How to Wire Set, How to Solder, Trouble Shooting.....	5
How to Erect Outside Aerial and Loop.....	10
A Good Crystal Receiver.....	13
A Selective Crystal Receiver.....	14
How to Change Crystal to Tube Set.....	15
Variocoupler Circuit Receiver.....	16
Split Variometer Circuit.....	17
Ultra-Audion Circuit.....	18
The Haynes Receiver.....	19
The Woods Circuit.....	20
Two Variometer Circuit.....	22
Two Variometer Circuit with Amplification.....	23
Honey Comb Coil Circuit.....	24
Two Variometer—Variocoupler Circuit.....	25
Reinartz Circuit.....	26
One Tube Reflex Circuit.....	28
Tuned Plate and Grid Circuit.....	29
Single Tube Four Circuit Tuner.....	30
Five Tube Four Circuit Receiver.....	32
Five Tube Neutrodyne Circuit.....	34
The Ultradyne, An Improved Super-Heterodyne.....	38
The Superdyne Receiver.....	43
Tuned Impedance Receivers.....	44
Tuned Radio Frequency Circuit.....	45
Two Stage Radio Frequency Amplifier.....	46
Audio Frequency Amplifiers, One, Two, and Push Pull Stages.....	48
Two Wavetraps.....	51
Symbols Used in Radio.....	52
How to Select Parts for Your Set, Condensers, Variocoupler, Variometer, Sockets, Etc.....	53
How One, Two and Three Circuit Receivers are Operated.....	62

The Wonder of Radio

The speed that radio waves travel through the medium of the ether has been measured for us by the scientists as being 186,000 miles a second. This speed is almost beyond human comprehension and can only be appreciated by comparison to speeds that we are familiar with. At a speed of 186,000 miles per second a radio wave, if strong enough so that it could be detected, would make nearly eight complete revolutions around the earth's surface in one second. In a recent experiment a single radio dot sent out from a powerful radio station was recorded a number of times in succession within a few seconds. Each time it completed the circle around the earth's surface it was picked up and recorded by delicate receiving instruments. At this rate of speed the radio wave would travel to the sun in the short space of eight minutes.

This characteristic of radio waves gives rise to many strange phenomena. The address of a speaker can be heard by a radio audience before the people assembled in an auditorium listening to the address directly, hear it. This is due to the fact that sound waves travel at a very low rate of speed as compared with radio waves. The speed of sound waves is only in the neighborhood of 1,080 feet per second as compared to 186,000 miles per second speed of the radio waves. The microphone in front of the speaker picks up the sound waves which are converted into electromagnetic waves, flashed off into space with the speed of light, detected and changed back into sounds by the radio receiver in a shorter space of time than it takes

for the comparatively slow sound waves to travel from the speaker's stand on the platform to the audience listening to the address. In this manner you will hear your favorite church service or dance selection, whichever it may be, before the audience receives the original sound coming through space.

The mystery of radio lies in the fact that very few listeners visualize what takes place between the broadcasting station and the reception of the electrical impulses by their receivers. Every one who listens in for the first time to the clear notes of a musical number or speech coming out of the receivers or loud speaker of a radio set tuned in on a distant broadcasting station cannot help but asking the question, "How can the program be so faithfully carried over the intervening distance between the transmitting station and your receiver without the aid of connecting wires of any kind?"

It was but comparatively few years ago that the same sort of amazement was shown upon the appearance of the telephone, which carried the sound of the voice between distant points over slender wires and reproduced the sound of the voice in the receiver on the other end of the wires. The telephone has come into such common usage that we accept its presence and action without question but here is radio which does away with the wires between the transmitting and receiving station. This is truly a remarkable accomplishment and appears very mysterious and little short of supernatural.

Hooking Up Apparatus for Experimenting

Unless one is fairly experienced at connecting radio apparatus it is strongly recommended that the various parts be assembled first on a table or board to become familiar with the proper connections, and to be sure that the hookup one is constructing will work satisfactorily. Then it also gives the operator a chance to see the various connections and to experiment to secure the proper values of the different articles under test. After the apparatus is working satisfactorily there is plenty of time to rebuild it in a compact unit and assemble it in a cabinet.

If the apparatus is of the table mounting type it is best to mount the whole thing on a plain board about eight inches wide, three feet long, and an inch in thickness. If the apparatus is panel mounting type a thin board about eight inches wide can be mounted on the edge of the base board for a panel. The practice gained in mounting the apparatus on the wood panel may save the price of a new panel for you.

Bell wire or number eighteen insulated wire should be used in making connections, which in a temporary set do not need to be soldered. Instead it is recommended that small spring clips such as are used to grip sheet music for display be soldered on the end of wires that are to be changed frequently so that connections can easily be made by clipping the end of wires or

binding posts. Old dry battery terminals can be mounted on the panel for binding posts.

If much work along these lines is contemplated it is a good thing to mount a variable condenser on a small panel separately so as to have a mobile unit that can be readily transferred from one location on the set to another without running long leads.

Remove Tubes from Sockets When Working on Set

NEVER attempt repairs with a screwdriver or a pair of pliers without removing the tubes from their sockets or removing the leads from the B batteries. The metal of your tool makes an excellent conductor of current and the possibility of burning out tubes by shorting two wires is so easy and such a common occurrence that this warning cannot be made too strenuously.

Careful wiring of your set so that the positive B battery leads, binding posts, and all connections are carefully insulated and spaced from adjacent wires will prove to be good tube insurance. In this day when Bus bar wiring, in which the wires are not insulated, is commonly used, you should carefully check the wiring of a new set before tying any tubes in the sockets. Be sure there is no possibility of the positive B battery wire being shorted onto some other wire or of wrong connections being used.

How to Wire Up Your Set

The manner in which your set is wired has a great deal to do with its success or failure. A few minutes of extra time spent on making good connections in the wiring will pay dividends later on in the satisfaction you will get from your radio set.

The reason for this is due to the fact that the amount of current picked up by the receiving antenna is so small that it can be measured only by delicate instruments. The resistance of the receiving antenna and the wiring of the set must therefore be as low as possible or the feeble current which is received will be cut down and the volume of sound reduced a great deal.

Connections made by wrapping one wire around another, or securing a wire around a binding post are all right for experimental purposes. The corrosive action of the air upon the wire will in time form a film of oxide on the surface of the wire which will greatly increase the resistance of the connection, and for this reason you should solder all connections on the set if they are to be permanent. Soldering makes a mechanical protection that will prevent this action.

Solder does not make as good an electrical conductor as the wire itself does and for that reason you should plan out the wiring of the set so that a long single wire can take the place of a number of short wires soldered together. In every hookup there are a number of connections that are common and can be connected with a single wire. For example the wire can be run

from the ground binding post to the binding post on the grid variometer, through that to the binding post on the filament rheostat and to the negative B and positive A binding posts. In this way you can sometimes run halfway around the set with one wire, with good contact on all the instruments and no soldered connections. This will often decrease the resistance of your set very materially.

The Kind of Wire to Use

You should use rather large wire in connecting up your radio set to keep the resistance of the set as low as possible, and to make the wiring self supporting and permanent. Number 14 soft copper wire will be satisfactory. Number 14 hard drawn or copper clad wire such as is used in the construction of aerials should not be used on account of its hardness, making it stiff to work. This type of wire is also brittle and a bend or kink in the wire cannot be straightened out without danger of breaking the wire. Acid soldering flux should never be used with copper wire as it will cause corrosion later on.

Hollow copper braid is next to Litz wire in efficiency and is very convenient to work with. It is a good conductor of high frequency radio currents on account of the large surface formed by the wires in the braid. It is very flexible to work with as it can be lengthened or shortened. A solid wire can be run inside of the braid to strengthen it, if desired to run over or under other wires. Where a connection

is to be made on a binding post the braid is pressed flat and a hole punched in the center. The braid can be soldered to as readily as to wire.

Number 14 tinned copper wire is the wire that is probably used the most. It is easy to work with, can be soldered to readily, presents a neat appearance, and is inexpensive. Square bus bar wire can be used and makes a very neat looking set if proper care is taken to see that the sides of the wire are even and square.

No Insulation Needed If the Leads Are Kept Sufficiently Separated and Wires Are Rigid

A short time ago varnished cambric tubing, usually called "Spaghetti," was considered a necessary covering for all wires in a radio receiving set. The standard form of wiring at the present time is the so-called "buss" wiring in which the wires are not covered with insulation.

One of the reasons for the change in style of wiring was that when spaghetti was used the tendency was to run the wires too close together with the feeling of security that the wires were so well insulated that no danger was present. True no danger was present from electrical shorting of the wires but the wires were not shielded magnetically from the electrical field that surrounds every wire that is carrying current. It is impossible to insulate the wire from the magnetic field of an adjacent wire but it is possible to reduce the transfer of energy between the two wires by running them at right angles to each other so that each cuts as little of the magnetic field of the other as possible. A wire should not run parallel with another wire for a very long stretch, and should not cross at a distance of less than one-half an inch from the other wire.

How to Make Neat Job of Wiring

In buss wiring all turns are made at right angles, and very few or no diagonal connections are made. With this type of wiring you are not apt to run wires too close to one another. As solid wire is used there is little danger of wires shorting and so insulation is really unnecessary.

Measure the distance between two points that are to be wired. Now bend a right angle turn in the wire so that one portion of the wire is equal to the vertical distance between the two points. Another bend should be placed in the wire at the correct horizontal distance between the points. In addition there is usually some lateral difference which will have to be taken care of by still another bend. The resultant wire should then be placed in the set and soldered to the two connections. This type of wiring will be readily understood by referring to one of the picture diagrams.

All Connections in A Radio Set Should Be Soldered

The average man who builds a radio set at home does not have a great number of tools to work with. For this reason he often passes up the expert's advice about soldering all connections as being unnecessary. He soon discovers, however, that he must tear his set apart later on and solder all connections to get his set to work properly.

The fact that you may not know where all the connections are going to go, or the shortest and most efficient arrangement of all the leads, may influence you to assemble the set without soldering the connections. It is advisable to assemble the set, especially if you are not accustomed to the work, and try it out in practice first. When the set functions satisfactorily, you should solder all connections permanently so that the electrical con-

tact will be positive and not be subjected to the high resistance which will be introduced later on if the joints corrode and become loose. Soldering will also prevent any connections from working loose so that they fail to make contact.

Practically one-half of the noise in a good many radio sets can be eliminated by soldering all connections, especially the aerial, ground, and battery circuits. This will greatly increase the pleasure you will get out of local concerts and is very necessary if you expect to receive long distance stations.

To prevent damage and to make future changes easier it is advisable to procure a few lugs for use on the rheostat and socket binding posts. These lugs should be in the form of small thin copper washers which have a protruding strip to fasten the wire to. The washer should be placed under the binding post and the wire soldered onto the protruding metal strip. This method enables you to get a good permanent connection without filling the threads up with solder, which you cannot help doing if the wire is soldered directly on to the binding post.

Apparatus You Will Need for Soldering

A soldering outfit can be purchased for a dollar or less and you will find it useful for small repair jobs around the home after the radio set is completed. A soldering iron with handle, sandpaper or a small file, flux, solder, and some means of heating the iron will be required.

Acid flux, commonly used by tanners, should never be used in radio work as it corrodes the wires so that the connections in your set are practically ruined after a short while in use. A small quantity of acid flux will be found helpful in keeping the iron clean and it can

be used for this purpose. Dip the tip of the iron in the acid flux just before using the iron. The flux in common use for radio work is in paste form. If you use that form of flux use it but sparingly and clean off the surplus with a brush soaked in gasoline. Never dip the point of the iron in this kind of flux as it causes a change in its chemical qualities, making it unfit for soldering use. Rosin flux is the best to use for radio work as it forms an insulator when cool, and for that reason does not have to be cleaned off.

How to Solder the Connections on Your Set

Heat the iron in a flame until it is hot enough to melt solder. File or sandpaper the sides and tip of the iron until a bright, clean copper surface is secured. Now place a piece of flux and solder on a piece of bright tin, and rub the faces of the iron on the spot so prepared, until the sides and tip of the iron have a tinny surface. If the iron has been improperly tinned the solder will collect in little drops on the surface of the iron and refuse to adhere to it. When properly tinned, and hot enough, the solder will "run" on the iron. The importance of properly tinning the iron cannot be overemphasized as the quality of the work will depend directly on this feature.

Clean all connections to be soldered with a small piece of sandpaper and place a small amount of flux on the prepared surface. Apply the hot iron together with a small amount of solder to the joint to be soldered, and hold until the wires become hot enough to allow the solder to run between the wires. The solder will not run until the wires become hot enough to melt solder themselves and for this reason you should hold the wires with a pair of pliers instead of in your hand.

Testing Your Set for Trouble

When a great deal of noise is present in your radio set disconnect the aerial and ground and listen to see if the noise is reduced. If it is, then more than likely your trouble is due to atmospheric disturbances or disturbances in the air. If the noise still is heard then the trouble is in the set.

First examine the B batteries. If a voltmeter is available test each cell in the battery to see if they are within 75% of their rated voltage. If you do not have a voltmeter you can safely assume that the batteries are all right if they are less than six months old and proper care has been given them. The next thing to examine is all connections in the set, especially the wires carrying the B and A battery currents. The most likely place for a loose connection in the B battery circuit will be in the contacts of the jacks or on the shaft of the plate variometer, where it is soldered to the wire running to the rotor or movable part of the variometer. This breaks sometimes in certain types of variometers due to the twisting of the shaft. The most likely places for poor connections in the A battery circuit, are in the filament rheostats and in the socket contacts.

If the noise has a long drawn out, booming sound, especially noticeable after the set has been jarred, then the trouble is due to the vibrating of the elements in the tube as explained before. If the noise is a bubbling or a frying sound, then it is very likely caused by irregularities in filament emission of the tubes due to surface impurities in

the filament, or to a slight amount of gas present in the tube. In either case the tube is at fault and there is no remedy except to try a new tube in place of the one giving trouble.

Many radio fans do not derive the greatest enjoyment from what is otherwise a good radio set because of the capacity effect of the operator's body. A distant station may be coming in fine, but when the operator removes his hand from the tuning dial to sit back and enjoy the concert, the station disappears or is replaced by a howl that necessitates replacing the hand or arm to its former position near the set to bring back the signal.

This is caused by the capacity of the operator's body affecting the tuning of the set and may be avoided by the simple matter of placing a grounded conductor between the operator and the instruments within the set. This is called "shielding." Perhaps the easiest method to shield a radio set is the tinfoil method. Select several sheets of tin or lead foil and carefully paste or glue on the insides of the cabinet and the rear of the panel. Care must be taken to cut away the tinfoil from all holes in the panel where shafts of instruments, screws, binding posts, etc., come through so as to avoid grounding these objects. The foil should not be trimmed away from around the ground binding posts, as this makes the connection of the shield to the ground. The shield on the sides of the cabinet must also be connected to ground to be effective.

How to Erect An Outdoor Aerial

The aerial is probably the first step you will take in the installation of your radio set. After erection it is soon taken for granted and dismissed from your thoughts, yet it is expected to remain aloft through rain and storms, collecting the feeble waves sent out by the broadcasting stations. The construction of this part of your radio installation should certainly receive the best of attention if you expect your set to reach out and bring in distant stations.

The lead-in of the aerial is an important part of your antenna system. Sometimes the effect of a good aerial is ruined by allowing the lead-in wire to touch the metal eavesputting or other objects that are partial grounds in dry weather and very good grounds in damp or rainy weather. This allows the energy received on the aerial to leak off to ground without going to your set. Any connection in the lead-in which is not soldered soon corrodes upon exposure to the weather and introduces a very high resistance which will cut down the feeble antenna currents very much.

Construct your lead-in of the same size wire that the aerial is made of and see that it does not touch the edge of the roof or the sides of the building. It will be best to run the wire along on insulators which will keep your lead-in from swaying in the wind or brushing against any objects. To be doubly sure, the lead-in wire can be made of insu-

lated wire and in this case you should take the best of precautions to see that the joint to the aerial is properly soldered. In a good many cases this connection will have to be made on the roof where it is difficult to get proper soldering facilities and your soldering iron will not be hot enough to work properly, and the result will be a "plastering" job of soldering which has not run solder in between the wires. The joint may look all right from the outside, but it is not a good conductor. If a joint is going to be necessary in the aerial, twist the wires and solder the connection properly before putting up the wire, for you will find it will be extremely difficult to solder this connection when the aerial is erected.

The lead-in should come down on the side of the house at approximately the place your set is going to be. It should now be brought through the wall by means of a porcelain wall bushing.

Selecting the Antenna Wire

Due to the fact that radio frequency currents travel on the surface of the conductor, braided and stranded wires are used a great deal for transmitting purposes. For practical receiving purposes this is almost negligible and is not recommended, due to the higher cost. The best wire, considering all things, is number 12 or 14 copper wire, soft, hard, or steel clad.

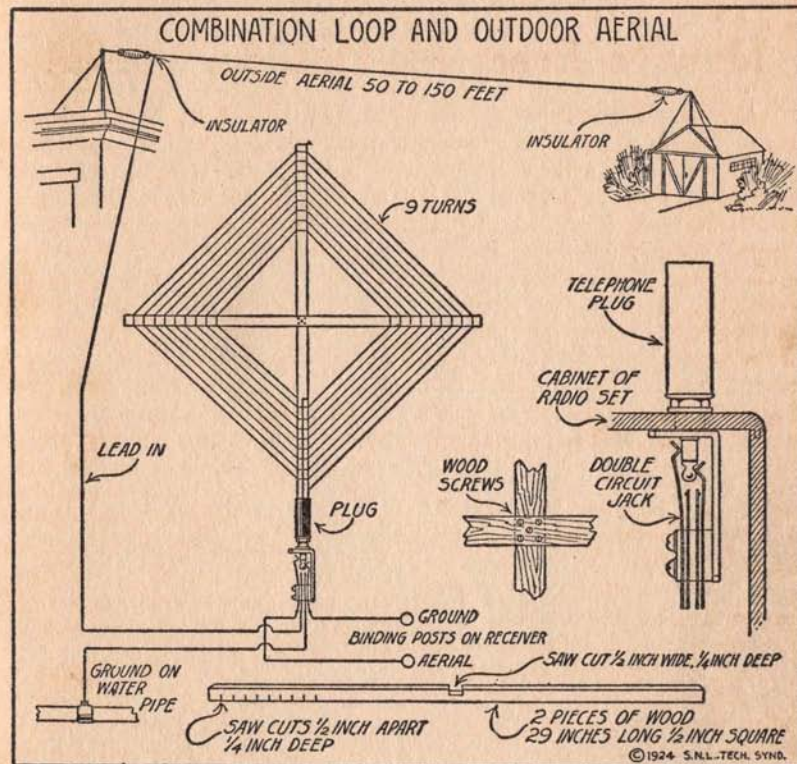

The loop is constructed on a wooden frame constructed of two cross pieces each one half inch square and twenty-nine inches long. Cut nine slots in each end of the cross pieces as shown in the illustration. Make these cuts with a hack saw approximately one quarter of an inch deep and one half inch apart.

In the exact center of each cross piece cut a slot one half inch wide and one quarter of an inch deep for the joint of the two pieces. Fasten the two cross pieces together with five small wood screws. On the bottom end of the upright piece fit an

ordinary telephone plug as shown in the illustration.

Use copper braid one quarter of an inch in width and approximately one sixteenth of an inch in thickness, commencing at the inside row of slots press the braid into the slots making the winding in a circular form as shown, connecting the two ends of the winding to the two terminals of the telephone plug.

A loop aerial will only be satisfactory on local stations unless radio frequency amplification is used. The above type of aerial is convenient when both types of aerials are desired, as a quick change can be made.

A Good Ground Connection Necessary to Get Best Results from Your Set

A good ground is every bit as important as the aerial, and the ground leads should receive the same attention and care during construction as the aerial lead-in. I am bringing this to your attention as it often receives very little care and may be one of the causes why your set does not work properly.

Use heavy wire for the ground lead, at least number 14 copper wire. This is necessary if a low resistance ground is to be obtained. This wire does not require to be insulated as in the case of the aerial lead-in, and can be concealed under the carpet when crossing the room, and run through the floor into the basement, if desired.

Copper braid makes an excellent ground wire and has the desirable qualities of being very flexible, strong, and can be flattened out so that it is inconspicuous and be run along in a crack in the baseboard of the room. You can make a permanent job by tacking the braid down to the floor so that it will not be in the way.

It is best to have the ground lead as short as possible and have it constructed of a single piece of wire without any joints in it. If joints are necessary see that they are all soldered in good shape. To provide against the possibility that your ground may not be as good as it is possible to secure, I would advise you to attach the ground lead to a number of different sources of ground. Attach it first to the water mains by soldering the wire to a ground clamp around the pipe, then run it to the sewer pipes and make a connection, and continue onto the

back yard, where the wire should be attached to a zinc or copper plate and buried beneath a foot of charcoal or ashes in a hole about four feet deep. The charcoal will assure you that the plate will be in moist earth and so make good contact with ground. The plate can also be placed in a cistern or well, and will assure you a very good ground.

A great many grounds for receiving sets are secured on water or gas pipes. These are usually satisfactory grounds, but sometimes they make a very poor ground and are responsible for the poor operation of the set, which is blamed elsewhere. The reason for this is that a good many pipes have the threaded joints cemented with white lead or paint to make them air or water tight. This is a high resistance and cuts down the efficiency of the set very materially.

A ground clamp is the best method to secure a good ground. Remember, the surface of the pipe where it is to be attached should be scraped or filed clean and bright, as the clamp will not make a proper electrical connection when used over paint or other protective covering of the pipe.

Cold water systems are to be preferred to those of the heating system so as to avoid the expansion and contraction of the metal which will make a loose connection in time. To make certain that your ground is satisfactory combine grounds secured in several places and run them all to the ground binding post on your set.

A Good Crystal Receiver

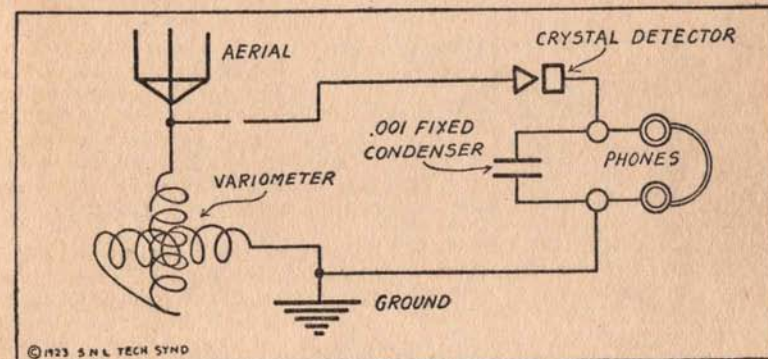
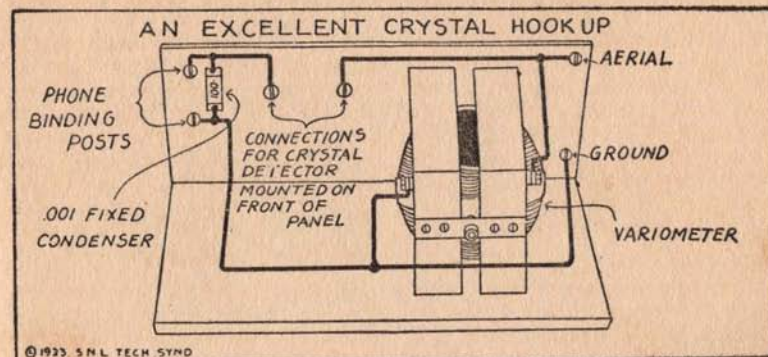

Here is one of the best crystal hookups. This receiver will receive broadcast programs from distances up to thirty or forty miles, and, in good weather, greater distances are often covered.

This would be a good set to build for your first one as the cost is very little, and you can later on convert it into a tube set. You are sure to meet with success as the connections are very simply illustrated in the diagram.

For an aerial a single strand of number fourteen copper wire, suspended between two insulators fifteen feet or higher from the ground will be sufficient. You will not have good results with an indoor aerial with this set unless you are located very near to the broadcasting station. Galena has been found to be one of the best crystal detectors to use.

A Selective Crystal Set

A SUPERIOR CRYSTAL RECEIVER

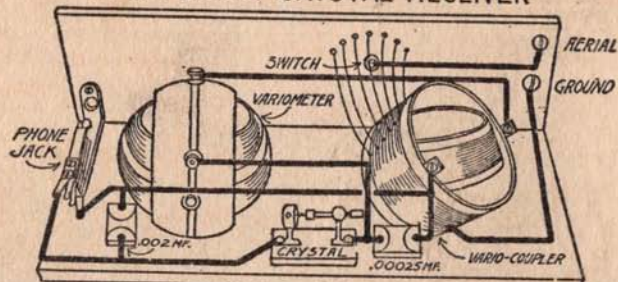

©1924 S.N.L. TECH. SYND.

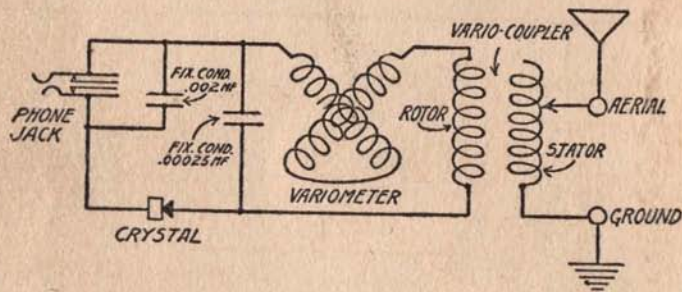

©1924 S.N.L. TECH. SYND.

This is a crystal receiver constructed with a variometer and a variocoupler. This receiver is more selective than the crystal circuit shown on the preceding page, due to the fact that a two circuit method of tuning is used.

The variometer and the variocoupler shown in the diagram are of the moulded type. Wooden instruments will function satisfactorily however. The coupler is shown with only one set of taps. Many types of variocouplers are provided with two sets of taps. In case you have the latter type, connect the ground wire to the first switch lever and run the

aerial to the second switch lever. See Woods circuit page 20.

A double circuit jack is shown for the telephone connections. This is used so that you can convert your crystal into a tube receiver and add amplification later on without the necessity of buying additional apparatus or changing the apparatus on the panel.

Two fixed condensers are shown. It is important to note that wires should never be soldered to fixed condensers as it will change their capacity. Bend a small loop in the end of your wire and fasten to the condenser by means of a small machine screw and a nut.

Converting Crystal Into Tube Set

CRYSTAL SET CHANGED TO TUBE RECEIVER

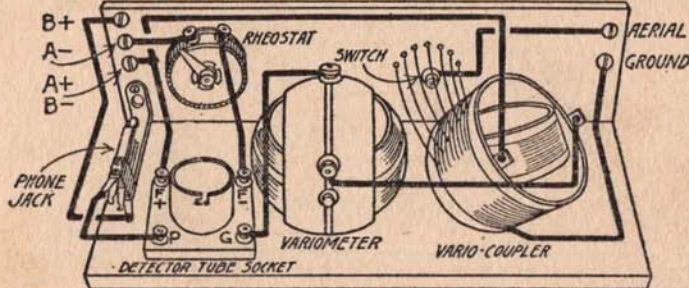

©1924 S.N.L. TECH. SYND.

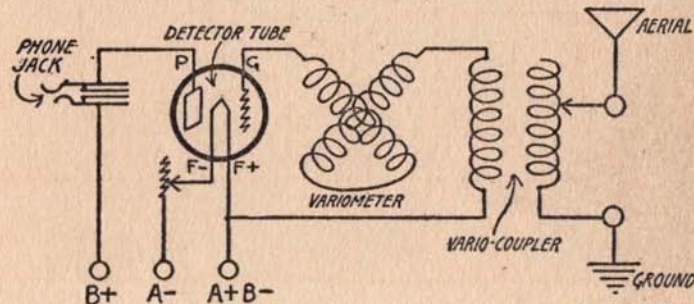

©1924 S.N.L. TECH. SYND.

This is a circuit showing how the same apparatus can be used to change your crystal set into a vacuum tube receiver. This is possible without changing any of the apparatus on the front panel, or moving any of the instruments.

The same apparatus can be used as shown on the opposite page in the crystal receiver with the exception of the crystal detector. The vacuum tube replaces the crystal as a detector.

Tuning will be very selective as in the case of the crystal receiver on the opposite page. This is be-

cause the circuit is of the two circuit type, with an extra tuning control in the grid circuit.

This circuit is not regenerative and for that reason will not re-radiate energy and interfere with nearby receiving sets. On the other hand it will not reach out as far as regenerative receiver set, but the quality of music will be much better. If additional volume and distance are desired, add two stages of radio frequency amplification and two stages of audio frequency amplification as shown at the rear of this book.

A Surprising Efficient Receiver Made with a Variocoupler

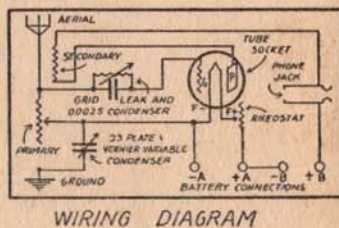
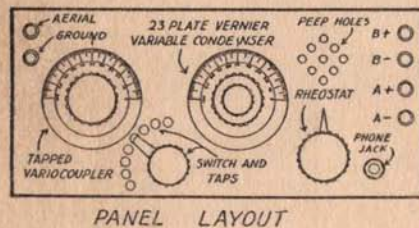
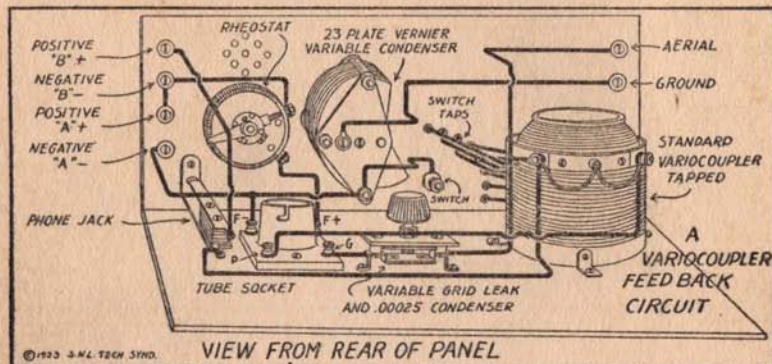

Apparatus Required

A variocoupler, twenty-three plate condenser, one .00025 M.F. condenser, one 2 megohm grid leak, one .002 M. F. condenser, one socket and rheostat for kind of tube used, eight binding posts, two switch stops, one switch lever, switch contacts for the number of taps on the primary of the variocoupler, headphones, detector tube, "A" and "B" batteries and wire will be the list of material needed to construct this set. The variocoupler should have at least seventy-five turns on the primary. The rotor should have in the neighbor-

hood of forty turns. If more, it may be found that later on some of the turns will have to be removed.

Tuning the Set

Turn the rheostat on until the tube lights up to the proper brilliancy. If this point is not known, then turn the rheostat about three-fourths on. Move the switch lever over the switch contacts, meanwhile tuning in with the variable condenser slowly until a signal is heard in the phones.

A Split Variometer Circuit

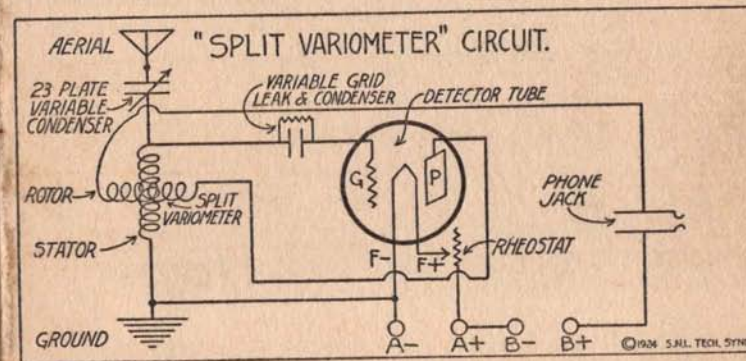
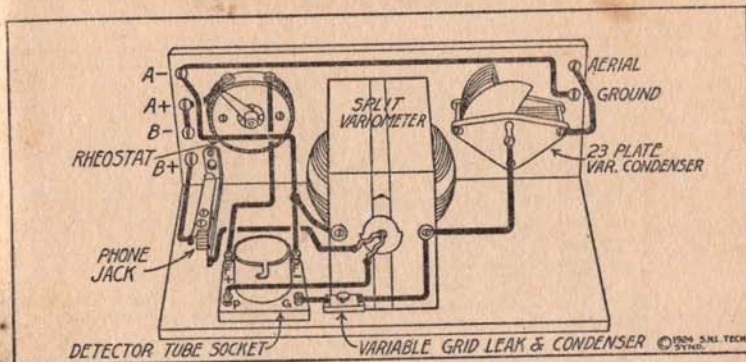

This is a very compact and easily constructed receiver made with a variometer. The circuit derives its name from the fact that the variometer is divided into two windings, similar to the winding of a variocoupler.

The primary winding is used for tuning inductance of the circuit, the rotor forming the tickler coil for the purpose of securing regeneration.

To split the variometer select the wire that connects the stationary and

rotating windings together. Cut this wire and use the two ends of the windings together with the regular binding post connections of the unit as shown in the picture diagram.

If a short aerial is used it may be impossible to reach the higher wavelengths with this receiver. In this case, connect the variometer lead which now runs to the rotor plates to the stator plates, and connect the rotor plates to the ground lead.

A Good Ultra Audion Portable Receiver

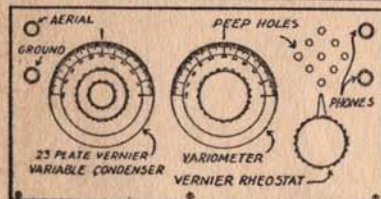
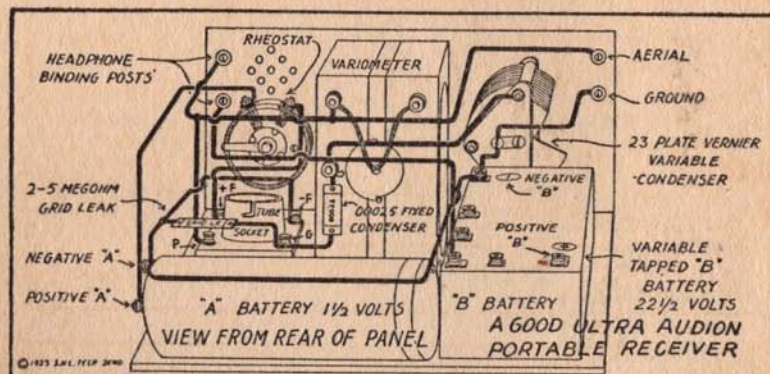

PANEL LAYOUT

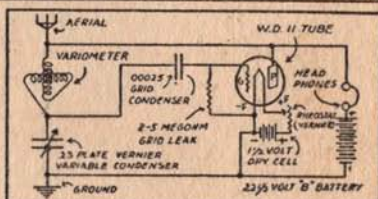

WIRING DIAGRAM

Dry Cell Tube Used

The diagram shows a set complete, including batteries and phones. This is a very convenient arrangement when dry cell tubes are to be used. The WD-11, WD-12 or the UV-199 can be used with a dry cell filament supply, thus doing away with the "overhead" of storage batteries, as well as the muss caused by their use.

If the UV-199 tube is used, a 25 ohm rheostat should be used with the "A" battery formed by three 1½ volt flashlight or dry cells

connected in series. The diagram shows only one dry cell, as this was constructed for a WD-11 tube controlled by a six ohm rheostat. The "B" battery in this circuit is the standard 22½ volt type, with taps. The connection should be made from the tap that gives the greatest volume. Try placing the positive connection on different taps while listening to a weak signal.

The variometer for the inductance forms a very efficient tuning control. The variable condenser is of the usual twenty-three plate variable type, but the use of a vernier condenser will aid greatly in tuning

The Haynes Receiver

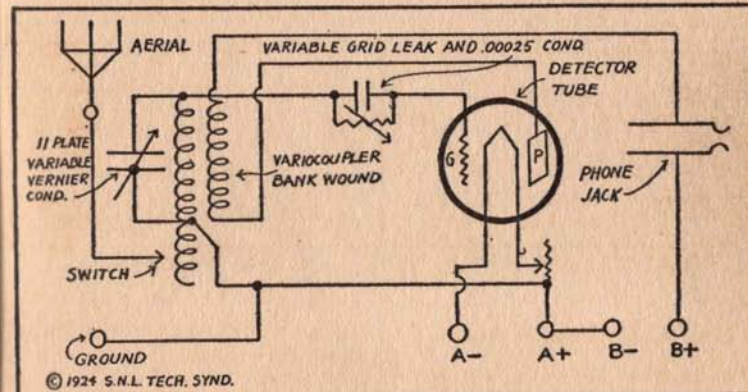
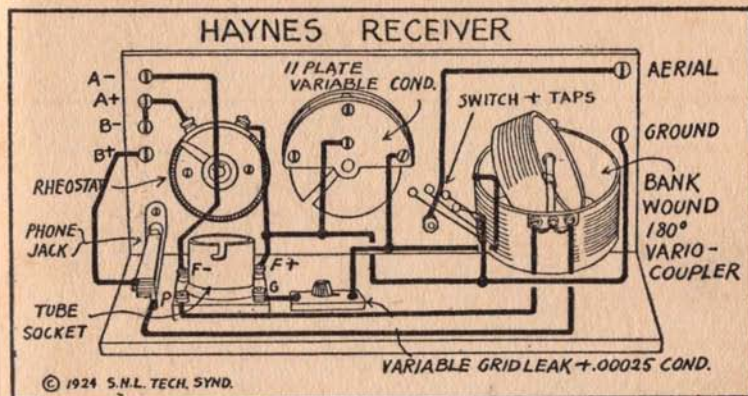

The Haynes receiver is an easily constructed set with a number of valuable qualities. One of them being that it is very easy to tune and at the same time being one of the most selective of single circuit broadcasting receivers.

The variometer must be specially wound for this circuit. Secure a plain variocoupler without windings or take the wire off from your present variocoupler. Wind the rotor with 35 turns of

number 20 cotton covered magnet wire. Using this size wire it will be necessary to bank wind the winding in order to get all of the wire on the rotor.

The stator of the variocoupler is wound with sixty-one turns of the same size wire. Starting at the top, wind on fifty-five turns then take a tap off to the rotor plates of condenser, then wind on six turns, taking a tap off to switch contacts at every other turn.

The Woods Circuit

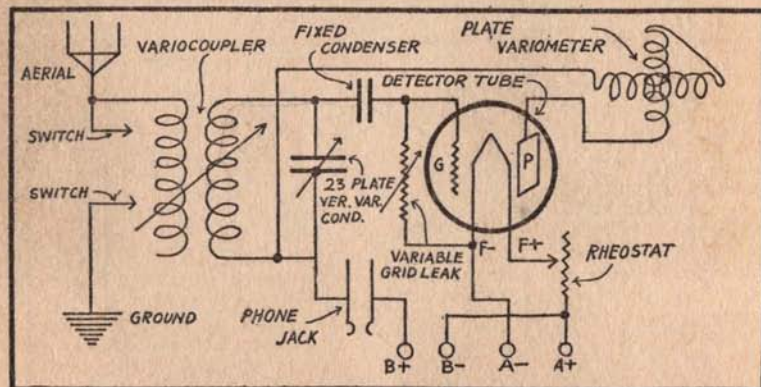
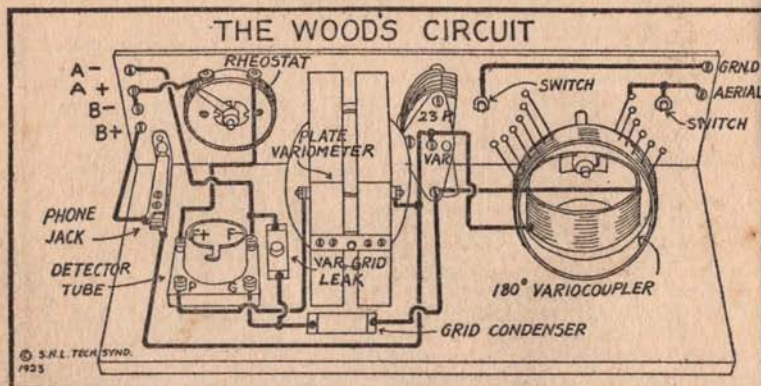

Reaches Right Out Through Interference and Brings in Distant Stations

An improvement has been made on the original Ultra-audion, as devised by Dr. Lee De Forest, by H. H. Woods, a radio engineer and experimenter of Chicago. Mr. Woods' circuit possesses several distinct advantages over the ordinary Ultra-audion circuit that make it a

distinctly novel hook-up in many ways than one.

The Woods' circuit is very sharp in tuning and for that reason is capable of reaching out through heavy interference to bring in out-of-town stations.

Building and Wiring the Set

In constructing this circuit use only the best parts and material obtainable. If poor parts are used don't blame the circuit if it does not come up to expectations. This advice applies especially to the variable condenser and the tube socket. Assemble the apparatus as shown in the picture diagram, with the variocoupler on the left, the variable condenser in the center, and the variometer on the right hand side, and the rheostat and tube socket on the extreme right. The aerial binding post is wired to the top tap on the primary of the variocoupler and to the left hand switch lever. This arrangement shorts out the turns of wire on the top half of the variocoupler that are not in use and reduces the dead end losses, so increasing the efficiency of the coupler. The ground binding post is connected to the right hand switch lever. The taps on the primary are connected to the switch contacts on the front panel as shown.

One side of the rotor of the variocoupler is wired to one side of the twenty-three plate variable condenser and to one side of the grid condenser. The other side of the grid condenser is connected to one side of a variable grid leak and to the socket contact marked "G". The other side of the variable grid leak is connected to the "F" terminal on the socket and the negative "A" battery binding post. The other side of the rotor of the variocoupler is connected to the other side of the variable condenser and to one terminal of the variometer and one side of the telephone jack. The other terminal of the telephone jack is connected to the positive "B" battery binding post. Negative B battery binding post is connected to the positive "A" battery binding post and to one side of the rheostat. The other side of the rheostat is connected to the "F" terminal on the socket. The plate contact on the tube socket is wired to the remaining terminal on the plate variometer and the connections are complete.

How to Tune the Woods Circuit

A circuit is good or bad according to its tuning qualities. By this I mean that if you have a receiving set that can be adjusted almost exactly in resonance with the incoming signal, then the volume from the set will be good on distant stations. On local stations the tuning of the set does not necessarily need to be fine in adjustment as only rough tuning is necessary to bring in the signal. On distant stations the set must be capable of adjustment to the point where the set is exactly in resonance as the wave is very sharp in comparison. You have no doubt noticed this fact while tuning in on a weak signal that a very slight turn on one of the dials will make the signal increase in volume a great deal.

You will find the Woods circuit capable of tuning very close to the wave length of a distant broadcasting station and for that reason it is very loud on distant stations providing you are careful in tuning in the station exactly. The rough tuning is done by means of the taps on the primary of the variocoupler. If the variocoupler is provided with two sets of taps, one set tapped every single turn and the other tapped at greater intervals, the tuning can be adjusted within one turn of the wave length of the station. Set the rough tuning switch lever on a tap and rotate the switch lever over the single turn taps. If you do not hear a signal change the lever over to the next tap and rotate the single tap lever over the contacts again. When a signal is heard turn the rotor of the variocoupler until the best volume is obtained. Now advance the variometer until the volume is satisfactory or until the music or speech becomes mushy or distorted. Turn back and bring the dial as close to this spot as possible without causing the tube to oscillate. This is the proper place to receive signals.

A Good One-Tube Set That Is Easy to Construct and Operate

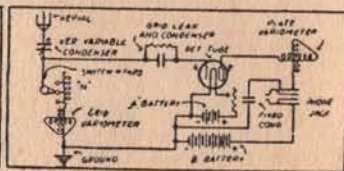
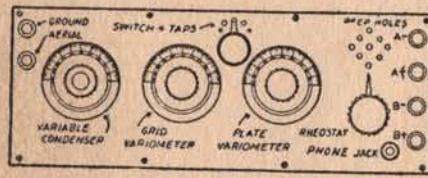
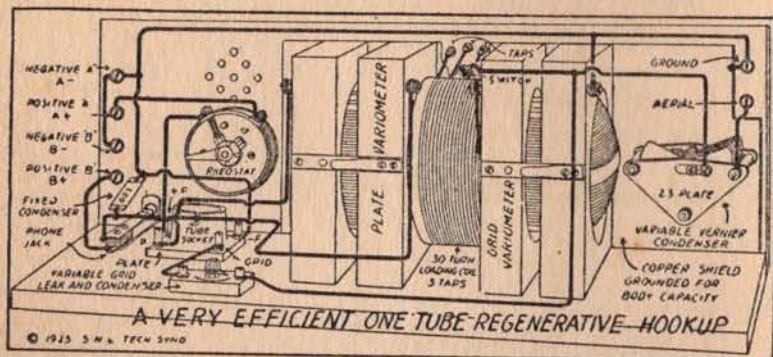

In the construction of the set, two variometers are used in conjunction with a $3\frac{1}{2}$ " fibre or cardboard tube 2" long, wound with thirty turns of wire. The tube is supported on the side of one of the variometers by holding it in position on the variometer, then melting some sealing wax around the inside bottom edge with a hot iron. When cool, this will hold the tube in position on the side of the variometer.

The tube is now wound with thirty turns of No. 20 cotton covered wire. First fasten end of wire to connection at side of variometer, then wind wire around tube, taking taps off at the tenth, twentieth and last turns. These taps are run to the switch contacts paced on the front of the panel between the vari-

ometer dials. Care should be taken to see that the wire is run around the tube in the same direction as the wiring on the variometer stator. The stator is the stationary or outside part of the variometer, the rotor is the round part inside the variometer that rotates when you move the dial. A twenty-three plate variable condenser, preferably a vernier, is used, on account of its broad tuning qualities. The grid leak may be a standard two or three megohm or a variable grid leak. The grid condenser should be of .00025 M. F. capacity.

After you have successfully completed the one tube circuit you can proceed to add two stages of audio frequency amplification as shown on the next page.

A GOOD REGENERATIVE RECEIVER

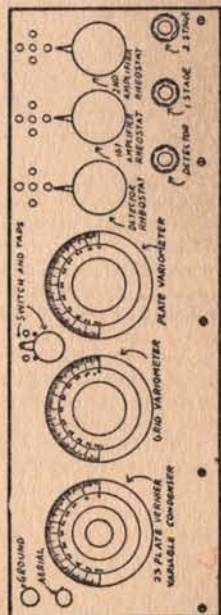
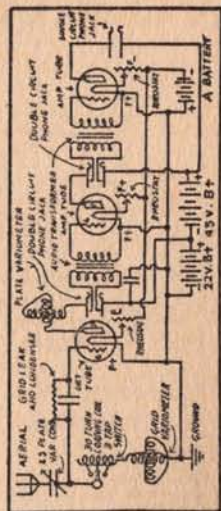
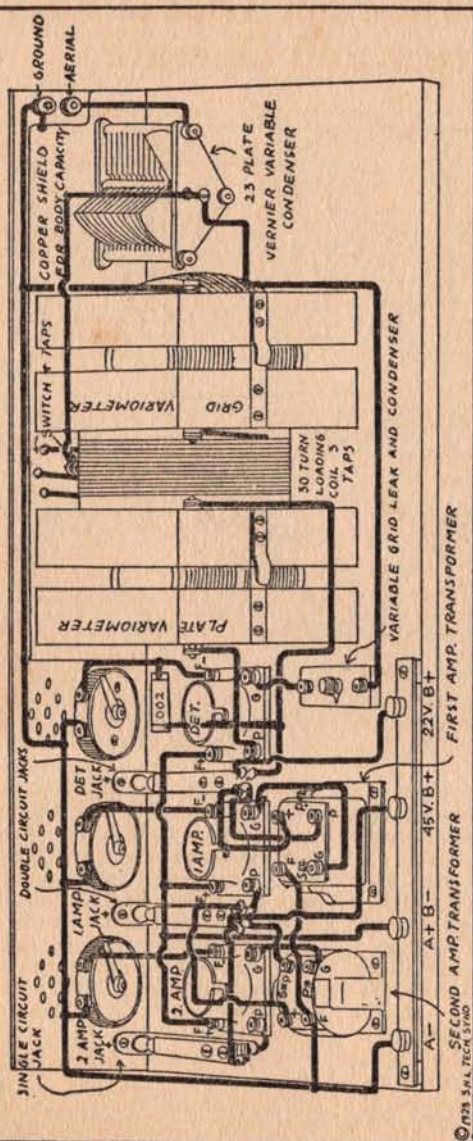

Honey-Comb Coil Circuit

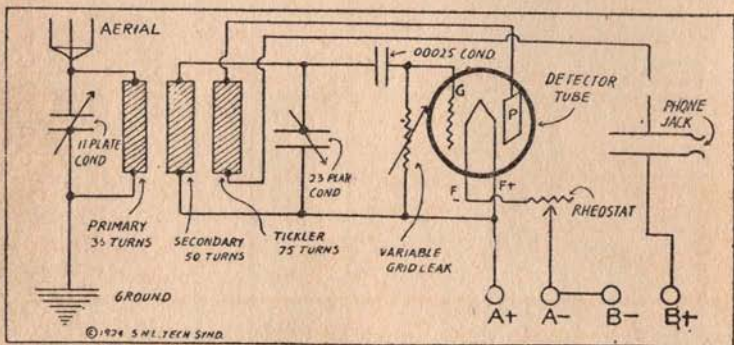
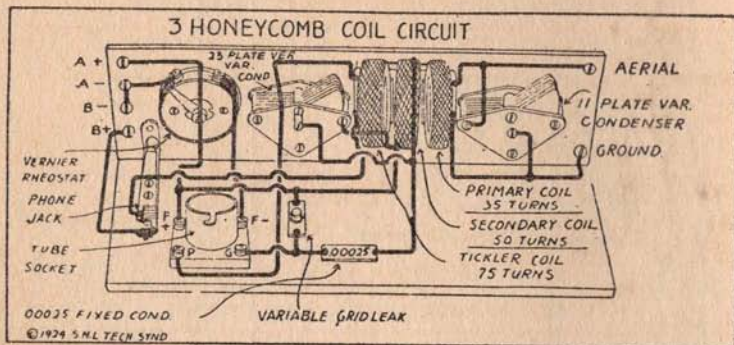

This shows a method of constructing the three circuit regenerative hookup by means of honeycomb coils.

Their use usually results in an increase in efficiency. This is due to the fact that the distributed capacity of inductances wound in lattice or honeycomb coil form of windings is lower than straight forms of winding.

One of the valuable features of honeycomb coils is their adaptability. Almost any wavelength can be reached by using the proper coils, and the coils can be changed in a few seconds as they are fitted with bayonet mountings so that

they can be readily slipped on and off the mounting.

For broadcasting wavelengths a combination of 30 and 50 turn coils for the primary and secondary coils and a 75 turn coil for the tickler winding operate satisfactorily.

The circuit is tuned by moving the honeycomb coils closer together or further apart, swinging them on a special mounting that allows the first and third coils to be moved with respect to the center coil. The two variable condensers tune the primary and secondary coils to the wavelength of the broadcasting station, regeneration being controlled by the position of the third coil.

Two Variometers and Coupler Hook-up

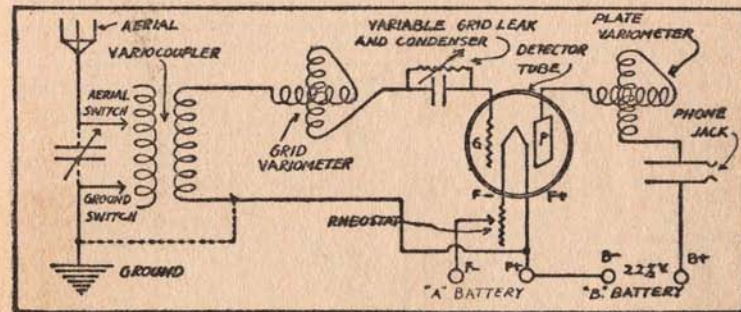
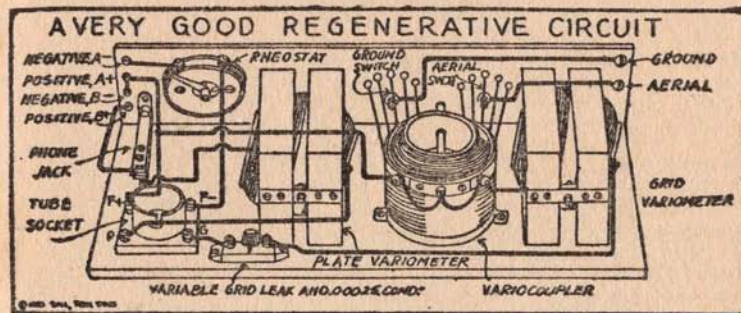

Easy to Construct and Tune with Great Selectivity, Distance and Volume

This is the standard three circuit regenerative circuit, sometimes called the "Armstrong," composed of two variometers and a variocoupler. The variable condenser shown in the wiring diagram between the switch levers can be added to raise the wave length, if you find difficulty in reaching the higher wave lengths. This is perhaps a little more apparatus than is used in the ordinary circuit and at first glance it may seem to be a little more complicated than the majority of circuits. On the other hand, it is really very simple to construct and the begin-

ner will have no trouble in following the wiring as given in the picture diagram.

Instructions on Tuning Set

Turn on the rheostat until the tube is lit up to normal brilliancy. Plug in with the headphones and tune in by means of the switch levers and the center dial. As soon as a signal is heard adjust the left hand dial controlling the grid variometer until the volume is loudest. Then adjust the right hand dial or plate variometer until the volume and quality are satisfactory.

Reinartz Hook-up for Distance and Volume

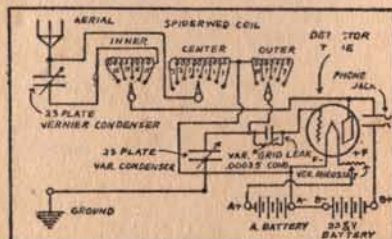
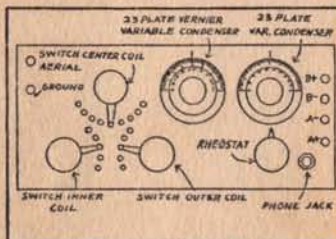
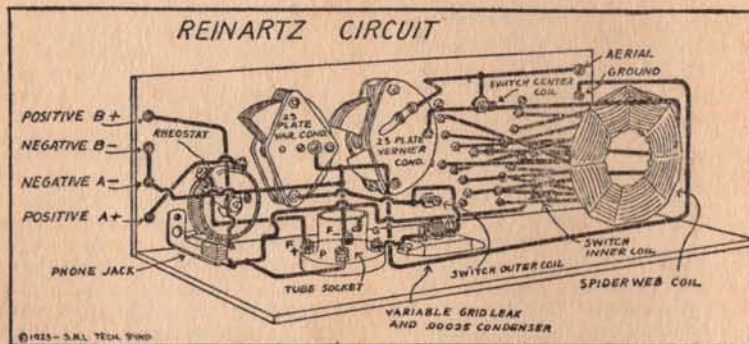

This is a circuit in which the feedback or regeneration is made by connection of the plate of the detector tube to the coil which also forms part of the tuning circuit. A condenser is connected between the plate of the detector tube and the antenna which adds a further control of regeneration in the set. The antenna circuit is not tuned and for that reason the aerial may be much larger than is ordinarily possible in sets where the antenna circuit must be tuned to resonance with the incoming signal. The tuning of the secondary is relied upon to se-

cure selectivity sacrificed by the untuned primary circuit.

Assembling the Set

The set should be wired according to the wiring diagram. When you wire the switch contacts to the taps on the coil you should be sure that the taps are taken in rotation, and that no coil is connected so that it is reversed and "bucking" the other windings on the coil. To avoid making a break in the winding of the coil at the places where the taps are taken off, make the tap by bending a loop in the wire, scrape

the insulation off, and solder to the LOOP in the wire. The inner coil taps are connected to the left hand switch contacts on the front panel, the center coil to the center contacts and the outer coil to the right hand contacts.

A soft detector tube should be used with this circuit, with 16 to 22½ volts of B battery. In actual use the circuit is quite similar to the ordinary single circuit regenerative set, regeneration here being controlled by the condenser between the plate of the detector tube and the antenna. The setting of this condenser does not affect the tuning of the set to a very great extent. This circuit has the disadvantage of all single circuit tuners in that the detector tube should not be allowed to oscillate or it will create interference with other receivers nearby due to reradiation of energy from the antenna. Also this circuit will be susceptible to interference from spark transmitting sets although very sharp in tuning to continuous wave stations and to distant broadcasting stations. The volume of signals with the Reinartz tuner is very good both in quality and loudness.

How Reinartz Set is Tuned

Tuning of the Reinartz receiver may appear to be a little more difficult than the ordinary receiver due to the number of controls used. The rough tuning is taken care of by the center and right hand switches. Of the two, the center switch is the most gradual, due to the lesser number of turns between

switch taps. When a station is heard the fine tuning is done by means of the right hand condenser which is placed across the main inductance.

When a station is tuned in by means of the two switch levers and the tuning condenser, the volume is brought up to the desired point by the left hand switch lever and the aerial condenser controlling the feedback of energy from the plate of the detector tube to the aerial circuit. This is similar in action to the ordinary plate variometer and the setting of this variable condenser will not change very much with different wavelengths. The use of this method of securing regeneration tends to minimize the capacity direct of the operator's body, yet it is advisable to shield the panel with a metallic shield, as the tuning is so sharp that you may have difficulty in keeping distant stations when a shield is not used.

Two stages of audio frequency amplification can be added to this set in the regular way with one exception. It may be found that the impedance of the primary of the transformer is not as great as the headphones and an additional inductance must be inserted in series with the primary of the transformer. If the transformer primary does not contain enough inductance the filament of the tube will have to be burned with more than usual brilliancy to make the set function properly. This inductance can take the form of a spider web coil wound in the same manner as the main inductance, however, much smaller in size and containing only six turns of the same size wire used in winding the other inductance.

A Highly Efficient Reflex Circuit

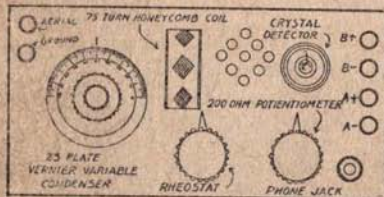
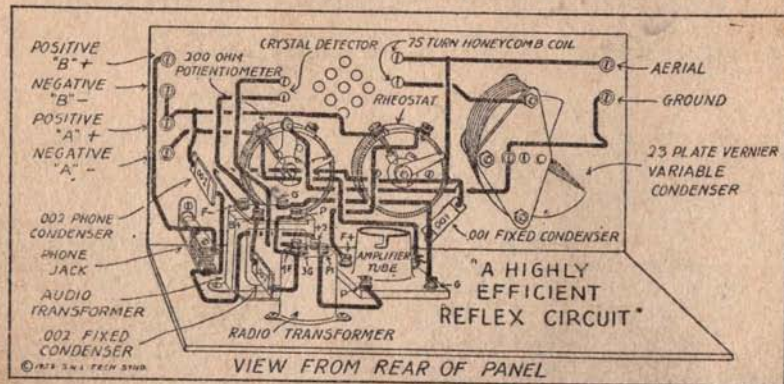

PANEL LAYOUT

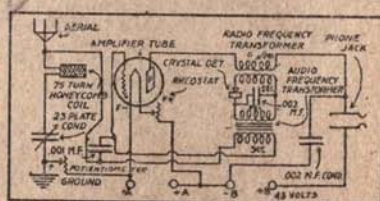

WIRING DIAGRAM

Properly Constructed Reflex Receiver Gives Greatest Efficiency and Volume for Least Material

If you wish to experiment with different hookups with the object of securing the greatest possible efficiency and volume from the least material, try some of the reflex circuits.

Adjustments to Make If Set Works Poorly

A 100 turn honeycomb coil may be substituted for the 75 turn if the set will not tune in some of the higher wavelengths. The capacity of the fixed condensers depends upon local conditions and it may be found beneficial to try other values in their place. If the crystal detector does not function as it should re-

verse the connections to the secondary of the radio frequency transformer or reverse these on the crystal detector. These connections are plainly marked in the drawing but mistakes are apt to occur in the assembling of the apparatus in which the transformer connections are reversed, or the crystal may be placed in the wrong direction to rectify the current. It is a good plan to try reversing these connections to see which works best. The position of the transformers in relation to each other often makes a reflex hookup a success or a failure. If the results are not what you expected, move the position of the transformers.

Tuned Plate and Grid Circuit

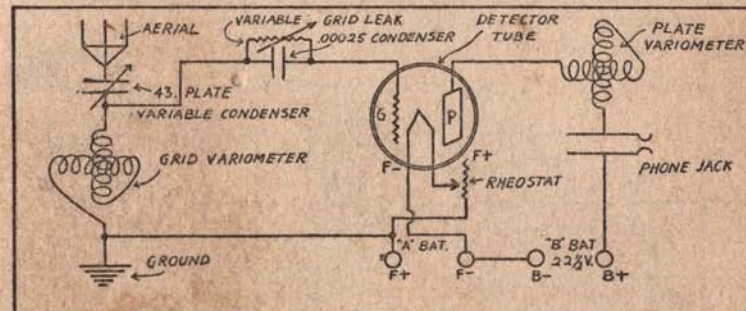
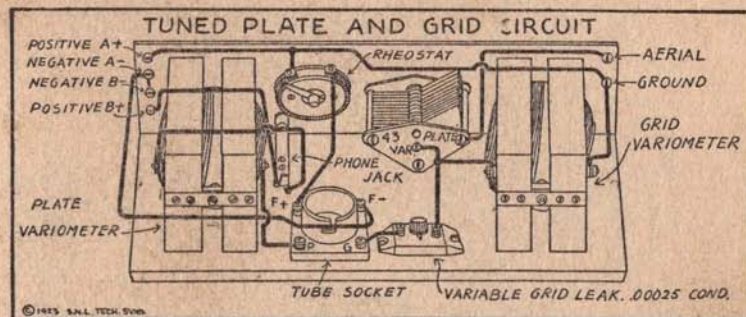

Hook-up Which Has Selectivity, Range, Volume and Dependability

The tuned plate and grid circuit is one of my favorite hookups on account of its easy tuning qualities, good volume, excellent range, and most of all, dependability. It is not a new hookup, but one that has been in use for a number of years, and is today used by the manufacturers of some of the best receiving sets.

The volume of the set is exceptionally good. There is always loss of energy in a radio set where the electrical impulses are transferred

from one circuit to another. The transfer of impulses from the primary of the variocoupler to the secondary by means of induction reduces the signal impulse to the grid. In this circuit the incoming signal is placed directly on the grid circuit of the tube, which makes this set louder than the two or three circuit tuner. The antenna and ground are a part of the grid circuit, and are tuned by means of the variometer and the variable condenser.

The Cockaday Four Circuit Tuner

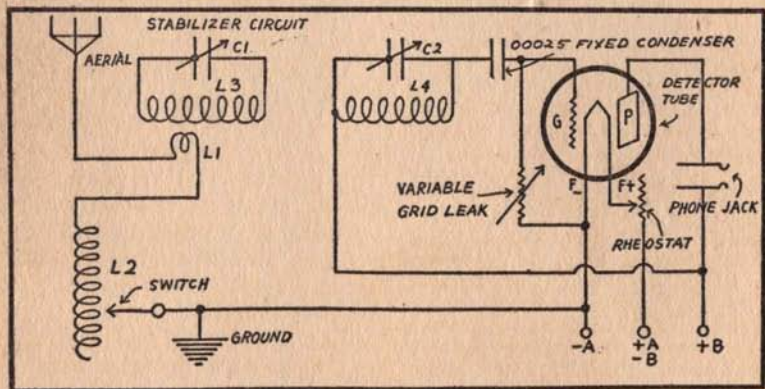
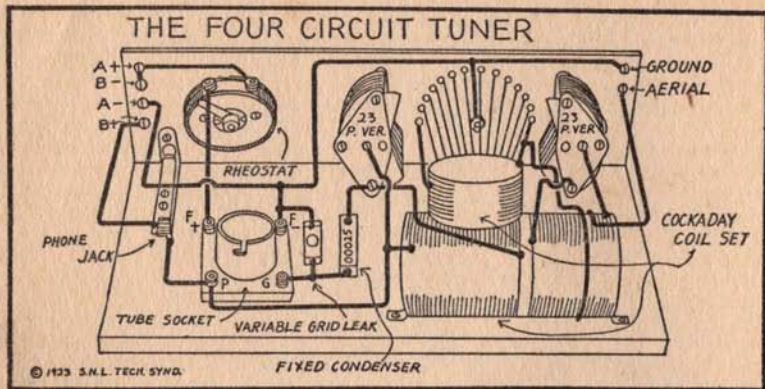

Try This Circuit for Selectivity and Quietness of Operation

After you have graduated from the easily tuned single circuit tuner into the more selective two- and three-circuit tuner class, you will need no urging to join the ranks of the four-circuit tuner enthusiasts. If you have yet to build your first radio set you will find the four-circuit tuner a good one to start on with the

assurance of results, not disappointments, with what you expected of radio.

Construction of Inductance for Four-Circuit Tuner

The inductances marked L3 and L4 on the wiring diagram are wound

on cardboard or bakelite tubing $3\frac{1}{4}$ inches in diameter and $5\frac{1}{8}$ inches long. Wind 34 turns of number 18 single cotton covered wire on one end of the tube for the L3 inductance. The L4 inductance is wound in the same direction on the other half of the tube, separated by a distance equal to the thickness of one turn of wire from the winding L3, and consists of 65 turns. The ends of the two windings should be fastened by daubing a little bit of sealing wax on the last few turns of wire or by punching two holes in the tubing in line with the last turn of wire and bringing the wire through the tubing and back to the outside surface thus securely anchoring it from moving.

The inductance marked L2 is composed of 43 turns of number 18 wire wound on the same diameter tubing as used in the construction of the inductance L3 and L4, and $1\frac{3}{8}$ inches long. This inductance should be in the form of a bank winding and taps should be taken off at the third, seventh, thirteenth, twenty-first, thirty-first, and last turns. If you do not understand how to bank wind a coil the winding can be made in a single layer on a tube three inches long with taps taken off as before. In assembling the apparatus this coil is laid flat against the side of the larger winding as shown in the picture diagram. The inductance L1 consists of a single turn of bus wire around L3 and placed about one-fourth of an inch from the end of the winding. Most radio stores now have these coils already wound.

Bank Wind Coil "L2"

Wherever the losses in a radio set must be as low as possible, as in the four-circuit tuner, it is common practice to bank wind the wire to reduce the capacity between turns.

Wind on two turns of wire on the tubing making sure that the wire

is as tight as you can wind it and that the two wires are against each other all around the coil. The third turn should be wound on top and between these two turns instead of adjacent to the second turn. The fourth turn should be wound on the tube next to the second turn, the fifth turn should be wound on top and between the second and fourth turn. If you only want a two layer bank winding the process is continued in the same manner with every other turn being wound between and on top of the last and second to the last turns. If a three layer bank winding is desired the sixth turn should be wound on top and between the third and fifth turns, the next turn being wound on the surface of the tube again.

The Tuning of Four-Circuit Tuner

The four-circuit tuner is of the Ultra-Audion type with an additional circuit which absorbs enough energy from the grid circuit to prevent the tube from oscillating when strong signals are received, and provides a very sharp control of regeneration. The set is tuned in first by means of the switch governing the primary inductance. When a signal is heard on one of the taps, adjust the right-hand condenser until the signal is brought in as loud as possible. Then adjust the left-hand condenser, which is in the four circuit, until the point of best reception or the elimination of the interfering signals has been reached. The vernier controls on each condenser should next be adjusted to provide the fine tuning. The tuning of the fourth circuit is not changed by further adjustments of the primary or grid inductances.

The Latest Five Tube Cockaday

Two Stages of Audio and Push Pull Amplifier Added to Original Circuit.

COCKADAY FIVE TUBE FOUR CIRCUIT TUNER

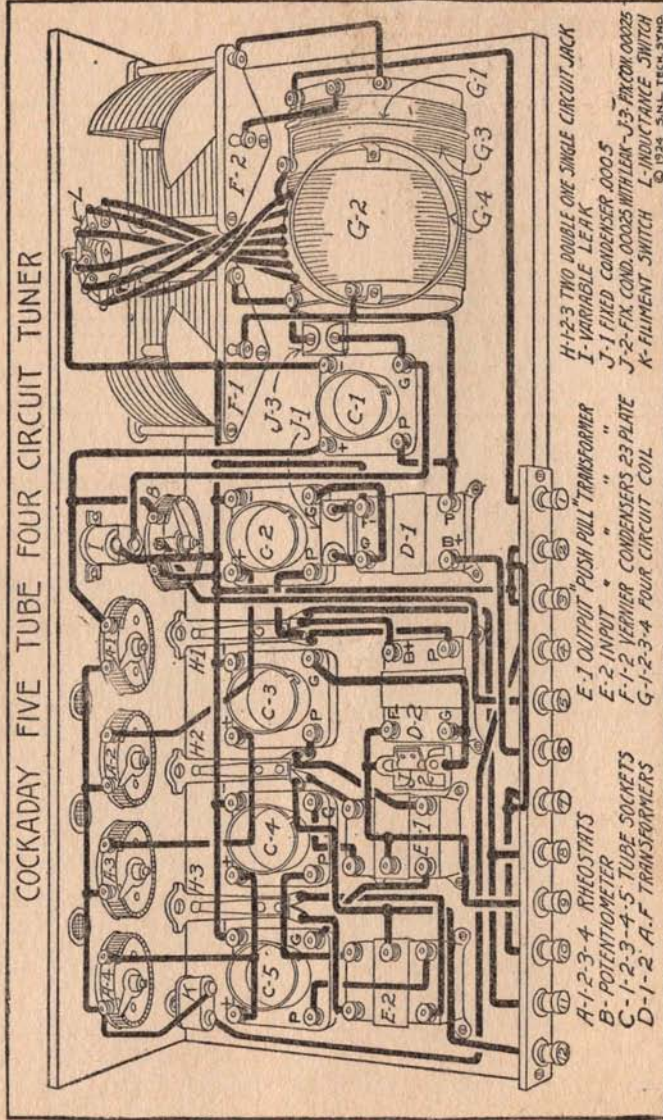

H-1-2-3 TWO DOUBLE ONE SINGLE CIRCUIT JACK
I-VARIABLE LEAK
J-1 FIXED CONDENSER 0.00.5
J-2-PTA COND. 0.0025 WITH LEAK-J3-PYCON 0.0025
K-FILAMENT SWITCH L-INDUCTANCE SWITCH
© 1934 S.N.L. TECH. 3740

E-J OUTPUT "PUSH PULL" TRANSFORMER
F-2 INPUT " " " "
F-1-2 VERNIER CONDENSERS 23 PLATE
G-1-2-3-4 FOUR CIRCUIT COIL

A-1-2-3-4 RHOESTATS
B-POTENTIOMETER
C-1-2-3-4-5 TUBE SOCKETS
D-1-2 A.F. TRANSFORMERS

Wiring Diagram of Five Tube Cockaday

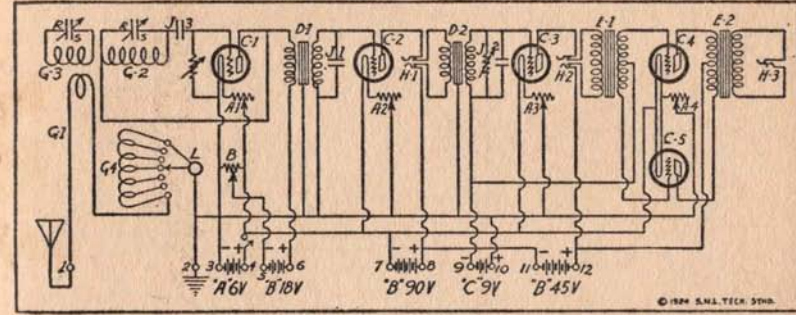

© 1934 S.N.L. TECH. 3740

The single tube four circuit tuner can be converted into the five tube set shown on the opposite page by the addition of two stages of audio frequency and a push pull amplifier. The tuning unit remains the same.

A number of changes are shown in the drawing, consisting mainly of more convenient methods of mounting the apparatus and arranging the different units. In place of switch contacts which require drilling a number of holes through the panel, an inductance switch requiring only one hole through the panel is used in the five tube receiver.

In the one tube receiver the binding posts are shown mounted on the panel. In the five tube they are mounted on an insulated strip at the rear of the baseboard to facilitate connections. A filament switch is added as part of the equipment to eliminate turning rheostats on and off.

Additional Equipment Necessary

In addition to the apparatus required for the single tube four circuit tuner, the following apparatus will be necessary to construct the five tube receiver. Two audio transformers (low ratio), one set of push-pull transformers, two double circuit jacks, four sockets, one variable grid leak, one fixed grid leak, 2 fixed condensers of .00025 M. F. capacity, three rheostats, a 200 to 400 ohm potentiometer, a filament switch, and additional binding posts and wire.

The numbers on the binding posts shown on the picture diagram read as follows: 1, Antenna; 2, ground; 3, negative "A"; 4, positive "A"; 5, negative 18 volt "B"; 6, positive 18 volt "B"; 7, negative 90 volt "B"; 8, positive 90 volt "B"; 9, negative "C" battery of three to nine volts; 10, positive "C" battery; 11, negative 45 volt "B"; 12, positive 45 volt "B".

Posts 2 and 3 are common and one binding post could be used for both ground and negative "A." Likewise posts 4 and 7. Also 8 and 11.

The Hazeltine Neutrodyne Circuit

The serious drawback to ordinary radio frequency amplification is that the capacity coupling of various units of the set produce distortion and a waste of energy. For example the grid and plate of each tube form a condenser as they are both conductors and separated by an insulating medium. When the grid circuit is in resonance with the plate circuit the condenser action affords a path for considerable feedback of energy in a cumulative manner until a condition of oscillation exists and your set commences to howl.

In the Neutrodyne circuit these capacity losses are balanced and nullified by the use of two small condensers which have a capacity of approximately 1.5 micromicrofarads each.

High Ratio Radio Frequency Transformers Used

The use of neutralizing transformers presents another valuable feature, that of allowing the use of high ratio radio frequency transformers. The usual radio frequency transformer cannot be used successfully if the windings have a higher ratio than 1 to 1 due to the choking action of the current when passing through the windings. In the neutrodyne the ratio of the transformers may be as high as 10 to 1, with the signal voltage being amplified as well as transferred from one circuit to another.

The neutralizing condensers and the radio transformers and condensers can be purchased at any radio supply house, the remainder of the apparatus is standard. The circuit at first glance would seem rather complicated, yet by following out the wiring in the picture diagram in conjunction with the wir-

ing diagram you should have no difficulty in building the set. The results to be derived from the circuit will bear out your expectations providing the set is carefully constructed and good materials are used.

The small 1.5 micromicrofarad condensers used in the Neutrodyne for balancing the capacities of the units of the circuit are very easily constructed from two pieces of number fourteen wire, a three-inch piece of spaghetti, a brass tube two inches long and five-sixteenths of an inch in diameter and two binding posts. Place the spaghetti inside the brass tube and run one of the wires halfway into the spaghetti. Fasten the other end of this wire in one of the binding posts. Now run the other wire through the binding post into the other end of the spaghetti tubing until the two ends of the wires are about three-eighths of an inch apart in the center of the tubing. The capacity of the condenser is adjusted by moving the brass tube between the binding posts.

The Neutrodyne, as well as all other radio frequency circuits requires careful wiring so that all leads are as short as possible and that wires do not run parallel with each other for a very great distance. The filament battery leads are excepted as any induction in these wires is of course negligible due to the fact that the battery connects the two, and the battery is grounded.

For the same reason the transformers are to be mounted at a sixty degree angle so that the windings will not be in inductive relation to each other. If this is not done a feedback of energy will take place between the windings that will cause distortion in the set and make it unstable in operation.

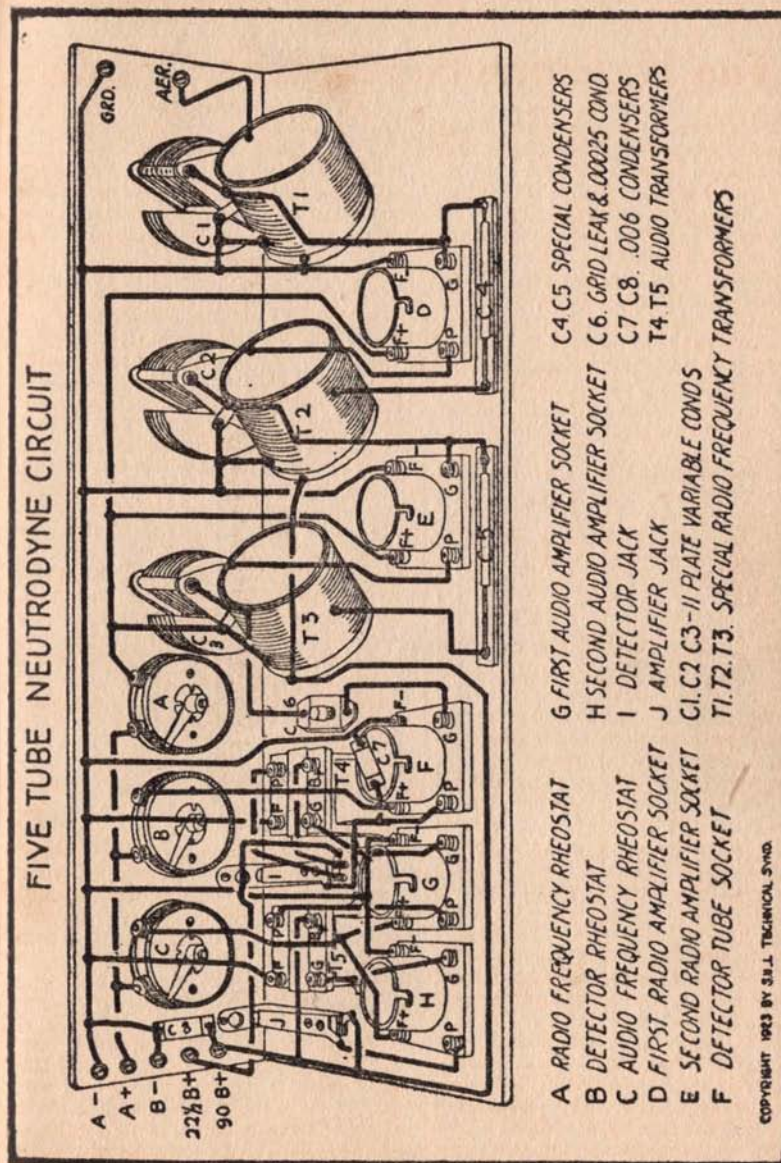

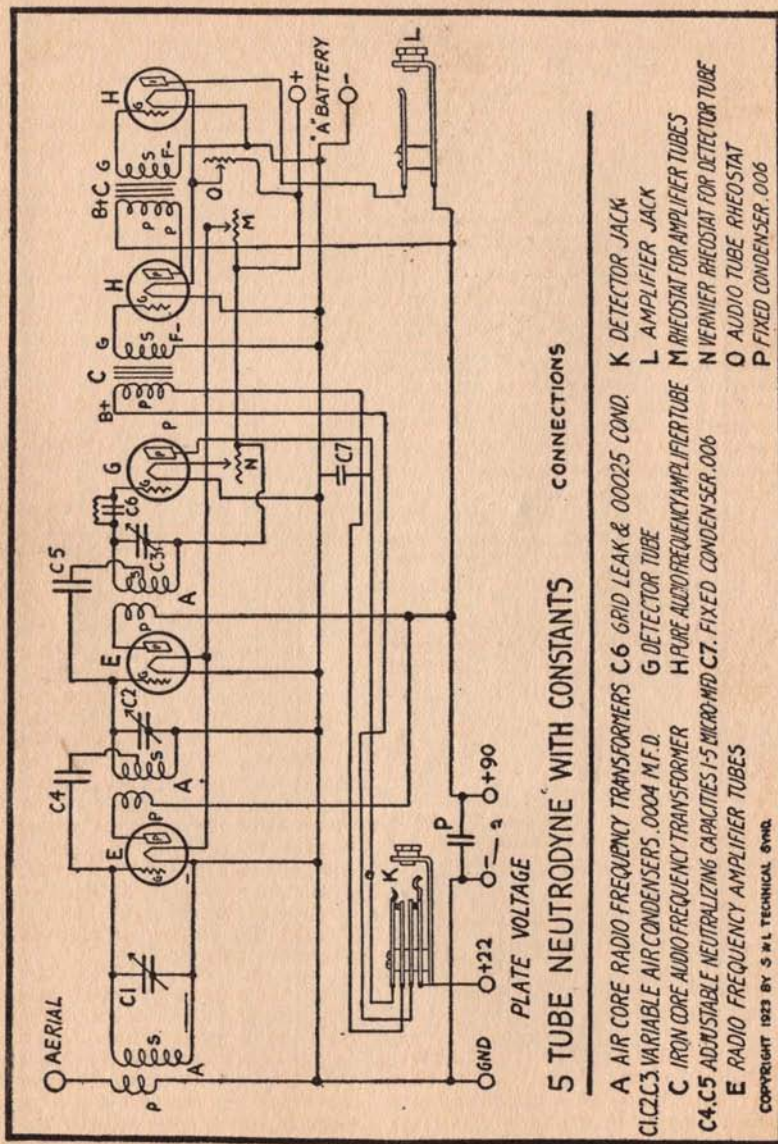

5 TUBE NEUTRODYNE WITH CONSTANTS

CONNECTIONS

- A AIR CORE RADIO FREQUENCY TRANSFORMERS C6 GRID LEAK & 00025 COND. K DETECTOR JACK
 C1, C2, C3 VARIABLE AIR CONDENSERS .0004 M.F.D. G DETECTOR TUBE L AMPLIFIER JACK
 C IRON CORE AUDIO FREQUENCY TRANSFORMER H PURE AUDIO FREQUENCY AMPLIFIER TUBE M RHEOSTAT FOR AMPLIFIER TUBES
 C4, C5 ADJUSTABLE NEUTRALIZING CAPACITIES 1-5 MICRO-MFD C7 FIXED CONDENSER .006 N VERNIER RHEOSTAT FOR DETECTOR TUBE
 E RADIO FREQUENCY AMPLIFIER TUBES O AUDIO TUBE RHEOSTAT P FIXED CONDENSER .006

COPYRIGHT 1923 BY S. M. TECHNICAL SYND.

How to Adjust Set

Insert the tubes in the sockets and connect up the filament and plate batteries. Turn up the rheostats until a hiss is heard in the phones or until a signal is heard. Tune the set, having the condenser dials all setting at about the same degree, until a loud spark or broadcasting signal is heard. Carefully tune this signal in until it is loudest.

Now remove the first radio tube, the one in the extreme left socket, and carefully retune until the signals again come in loud. Place a small piece of paper over the filament contacts of the tube, then insert the tube in the socket. This is done to allow the plate and grid leads of the tube to make contact yet to prevent the tube from lighting and operating. Signals will probably be heard in the phones again. Move the brass tube of the first neutralizing condenser (the one on the left hand side of the set) until a point is reached where the signals are very weak or disappear entirely and no sound is heard in the phones.

Remove the paper from the contacts of the tube and replace the tube in the socket. The signals will again reappear. Now repeat the same process with the second radio frequency tube and adjust with the second neutralizing condenser.

The setting of the neutralizing condensers should now be locked in place by a drop of melted sealing wax placed on the ends of the brass tubes and the insulated covering of the wires.

If you find it difficult to properly balance out the circuit in this manner it indicates that you may have some connection wrong in your wiring such as a reversed filament connection on some of the tubes

With some neutrodyne receivers it is practically impossible to neutralize the capacity of the tubes. This may be due to the fact that the wiring of the radio frequency part of the set has been made in such a manner as to add a greater capacity to the circuit than the neutralizing condensers can balance.

It may then be necessary to completely rewire the radio frequency part of the receiver. Try neutralizing your receiver on a very weak signal. Move the neutralizing condensers very slowly and stop at the point where the signal becomes loudest and the whistle ceases.

How to Tune

The three variable condensers tune the transformers to the incoming signal and you will find that the setting on each of the dials should be practically the same. That is, if the first dial is setting at 40 then the other dials should be placed approximately at the same position and read 40 also.

This characteristic of the set makes it rather difficult to hunt for signals but on the other hand is especially valuable for the setting of the dials for one station can be recorded and the station readily tuned in the following night by merely setting the dials of the condensers at the marking where the station came in before. Your success with the set will depend a great deal upon the log you keep of the number of stations you have picked up and the setting of the dials to bring them in again.

A very close adjustment is necessary to bring all three condenser dials to a point where the transformers are exactly in resonance with each other and to the incoming signal. When the first dial is moved slightly the other two will have to be moved correspondingly to tune in with it and bring the signal in.

The Ultradyne

An Improved Super-Heterodyne

An improvement on the Super-heterodyne receiver has been developed by Mr. Robert E. Lacault, a prominent radio engineer and writer. He gives it the name of the Ultradyne.

In a search for a super-heterodyne receiver that would actually "deliver the goods," I tried out a total of five super-heterodyne receivers. In every case I actually built up each type, using transformers and circuits for that particular type of super-heterodyne.

Several of the circuits used nine and ten tubes. With nine tubes, using transformers manufactured expressly for the circuit, it was possible to bring in a number of stations within a distance of a thousand miles with fair volume.

Loop Used

On all of the five sets a twenty-nine inch square loop was used, shunted by a .001 M. F. variable condenser. The same batteries and tubes were used and the experiments were made in the same location in order to compare results obtained from each circuit.

Each receiver was built up with two stages of audio frequency and a loud speaker was used throughout in all the tests. In order to give every receiver a fair show two weeks were spent on each receiver. Every possible experiment was made on each circuit by changing transformers, condensers, oscillator coils, etc., to see if better results could be obtained with each receiver.

If I was unable to secure satisfactory results in adjusting and tuning any circuit in two weeks' time it certainly was not suitable to present to less experienced radio fans than myself.

No Distance

I visited several experimenters who had built up the super-heterodyne type of receiver and who were having good results. In every case they confessed that several months of careful work was necessary to secure the right adjustment of the apparatus used so that results were satisfactory.

The coupling of the oscillator coil is extremely critical and requires a great deal of experimentation in the average super-heterodyne circuit.

The receiver shown in the diagram functioned when first assembled and equalled, on six tubes without any amplification, any of the other types of super-heterodynes with two stages of audio frequency amplification. It also brought in distant stations on the loud speaker that it was impossible to hear on the other sets even when using headphones.

Not Hard To Construct

A passing glance at the picture diagram would give you the impression that the circuit is very difficult to construct and operate. In reality the reverse is true.

If you have had little experience in building radio receivers of any kind I would not advise you to attempt this one as your first. While no trouble should be experienced due to the fact that every piece of apparatus is plainly marked and shown in position, if trouble should develop it may be rather difficult for you to find the cause and remedy it.

The cost of the various parts to construct this receiver is over one hundred dollars and my only reason for presenting such a complicated receiver is to give the dyed-in-the-wool experimenter a chance to go the limit.

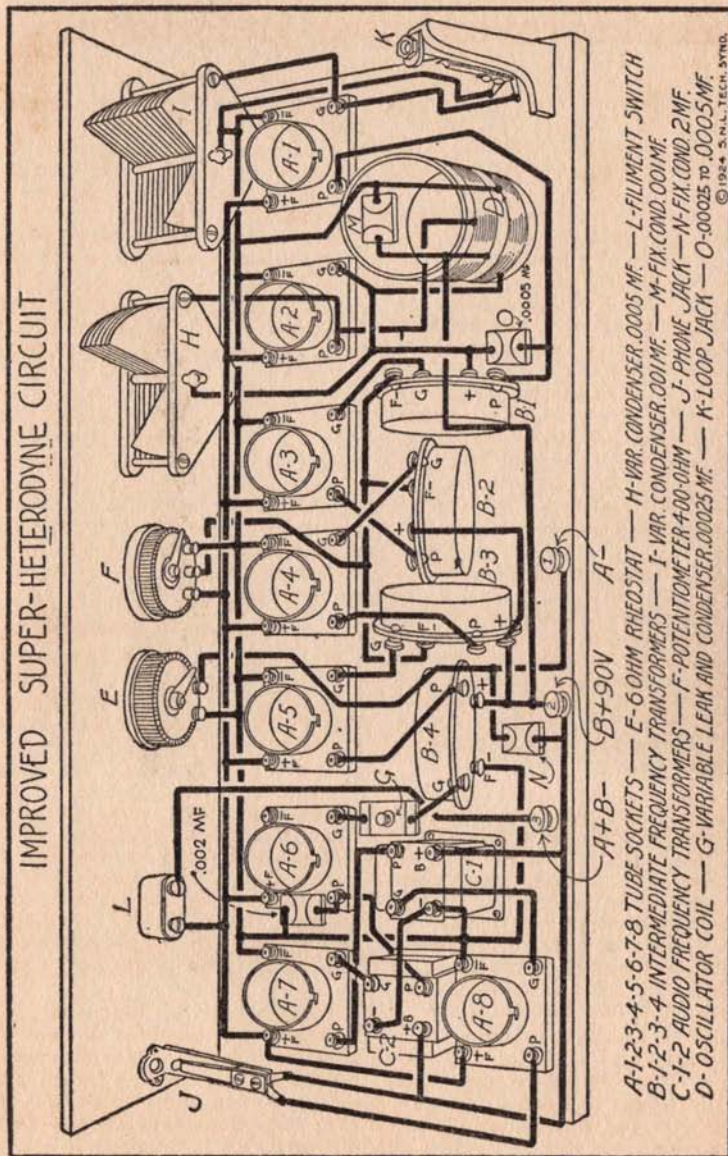

Sockets, Condensers, and Transformers Main Items

The picture diagram of the Super-heterodyne might lead you to believe that an enormous amount of material was required to construct this receiver. The main items are the sockets, condensers, and transformers.

Being an eight tube receiver the tubes will be the most important item. UV 201-A tubes throughout function satisfactorily. If you desire the second or oscillator tube may be of the Western Electric 216-A and the sixth or detector tube may be of the UV 200 type.

In this case it will be necessary to incorporate a separate rheostat in the circuit for the oscillator tube and one for the detector tube. Both should be of the six ohm or of the graphite resistance type. You will have better results if a separate rheostat and tube are used for the oscillator tube.

Eight sockets will be necessary. The two condensers shown are of the vernier type but a plain condenser can be used in either case if you have a micrometer adjustable dial. The tuning condenser should be of .0005 M. F. capacity. The oscillator condenser should be of .001 M. F. capacity. Be sure to secure condensers of good quality with low end losses.

A potentiometer, 2 single circuit jacks, 1 battery switch, 3 binding posts, 1 six ohm rheostat (three if detector and oscillator tubes are to be operated separately), 1 .001 M. F., 2 .00025 M. F., 1 .00025 and .0005 M. F., and one 2 M. F. fixed condensers will be necessary.

Four radio frequency transformers, seven inches of micarta or bakelite tubing of three inch outside diameter, one variable grid leak will also be required.

The receiver will require a panel 7x28 inches and a cabinet 7x28x7 inches deep. A baseboard 7x27x6 inches will be needed. Bus bar wire, screws, a quarter of a pound of number 20 double cotton covered wire will complete the requirements.

Don't ruin your chances of success by buying inferior apparatus to construct your receiver. Buy good parts made by a responsible manufacturer.

How to Wind Oscillator Coils

The oscillator coil for the super-heterodyne receiver is wound on a piece of three inch tubing four inches long. This tube should be of paper, bakelite, or some other very good insulating material.

The windings of this coil are made with number 20 double cotton covered wire. The coil is made in two sections each wound in the same general direction on the tube. The first section, which is connected between the grid and the filament of the tube is composed of 24 turns wound in a single layer.

The second section of the oscillator coil is wound commencing about a quarter of an inch from the end of the first winding and continuing in the same direction for 32 turns. The two windings are connected to one side of a .001 M. F. fixed condenser.

How to Wind Transformers

The intermediate transformers shown in the Super-heterodyne receiver can be easily constructed without the aid of machinery or special apparatus. If you desire to buy manufactured transformer be sure to obtain AIR core and not iron core transformers, as the latter type will not give best results in this circuit.

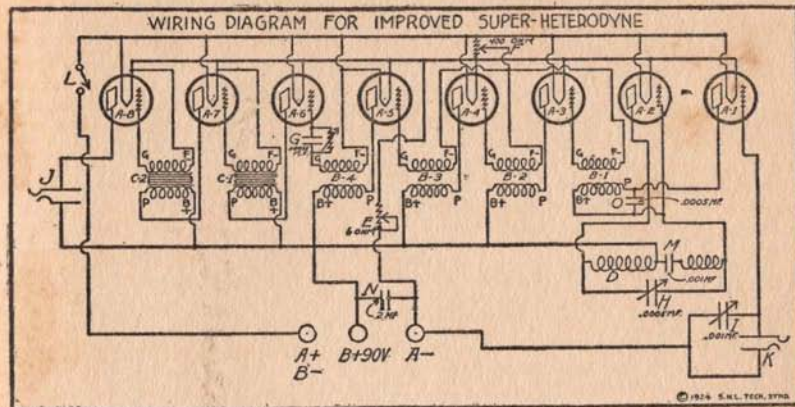

For the winding a special spool must be constructed. In reality it consists of three spools connected together. For the experimental transformers I used four celluloid dial plates and three wooden washers held together by a brass bolt. Disks 3½ inches in diameter constructed of gray fibre or bakelite can be used in place of celluloid dials.

One wooden washer should be ¼ inch thick and 1½ inches in diameter. This should be used for the center washer on which the primary winding is made. The secondary winding is made on a wooden washer ⅛ inch thick and one inch in diameter. Two of these are required for each transformer.

A hole should be drilled through the exact center of each washer and insulating disk that will accommodate a quarter of an inch brass rod. One end disk should be a half inch larger in diameter than the others in order that binding posts can be mounted on this side.

Assemble the large disk on the bolt, then one of the washers one inch in diameter, then another disk, a large wooden washer, a disk, a one inch washer, another disk, and the nut on the rod. Screw the nut

on tightly and you will have a spool having three slots in it.

The center slot is for the primary winding which should be composed of 500 turns of number 30 single cotton enamel wire. The inside end of the wire should be brought out to a binding post on the large washer and marked plus B. The outside end of the winding should be secured on a binding post and marked P.

Take care to keep the amount of tension of the wire constant during the time you are winding the primary or the characteristics of the transformer will be changed.

Secondary Winding Given

The secondary winding of the intermediate transformers is composed of 550 turns of number 32 single cotton covered enamel wire wound in each slot on each side of the primary, the winding being in two sections. The two sections may be wound without a break in the wire but passing it over the primary winding from one section to the other.

It is very important at this point to mention that the winding of the secondary sections of 550 turns each, and the winding of 500 turns of the

primary should be made as near exactly to the above specifications as possible and should be wound in the same DIRECTION. Also try to maintain the same tension on the wire throughout the winding.

Once the windings have been completed it is advisable to secure the last turn to the remainder of the winding by a drop of sealing wax.

The ends can now be fastened to the four binding posts placed on the larger disk and soldered.

The beginnings of the primary winding should be marked plus B. The end of this winding should be marked "P". The beginning of the secondary winding should be marked "F.", the end being marked "G."

The primary of the first transformer is wound with only 300 turns No. 30 S. C. E., the wavelength being raised by the placing of a .00025 M. F. condenser across the primary winding.

Adjustments to Make

Anyone can construct a receiving set yet few go further and put on the finishing touches that spell success or failure of the undertaking. There are certain minor adjustments that are necessary to all receiving sets before they will function at their best.

In the super-heterodyne receiver it is a good plan to completely shield the oscillator coil and the modulator tube by means of copper sheeting to prevent the feeding of energy from these parts to the rest of the circuit. This shielding should be completely around the oscillator coil and should be around the modulator A1 and the oscillator tube A2. This shield does not necessarily need to be grounded.

An additional improvement that can be made is to supply two additional rheostats, one for the oscillator "A2" and one for the detector tube (A6 in the diagram). This will enable you to secure a more accurate

adjustment of these tubes, which are more critical than the others.

It is a good idea to try the tubes around in different sockets so that the proper tube for the purpose is found.

Tuning the super-heterodyne receiver is fairly simple. Move the tuning condenser "I" a few degrees at a time, and then vary the oscillator condenser "H" slowly over the complete scale for each setting of the tuning condenser.

A station should be heard at two different positions on the oscillator condenser. Use the position that gives the best results. If a whistle is heard turn the potentiometer until the whistle disappears and then advance the pointer towards its former setting until maximum amplification is secured.

Now adjust the rheostat until the station comes in clear. Remember that the loop is directional in effect. Vary the setting of the loop until signals are loudest.

Aerial Can Be Used

The Super-heterodyne receiver can be used with an outside aerial very successfully. In this case an additional coupling coil or tuning coil will be necessary. A short antenna is preferable to a loop for a greater signal strength will result.

This coupling coil should be wound on a piece of mica or bakelite tubing three inches in outside diameter and approximately six inches in length. Two windings are made on this tube.

The winding for the untuned primary consists of eight turns of number twenty double cotton covered wire in a single layer commencing one half inch from the end of the tubing. The secondary winding is composed of 72 turns of the same size wire wound in the same direction and with a spacing of one and one half inches from the end of the primary winding.

The Superdyne Receiver

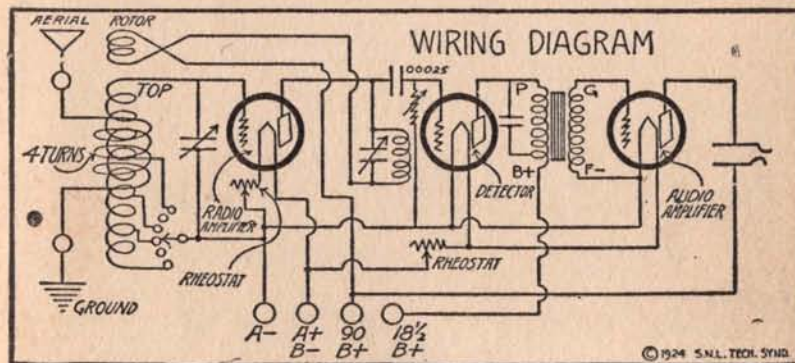
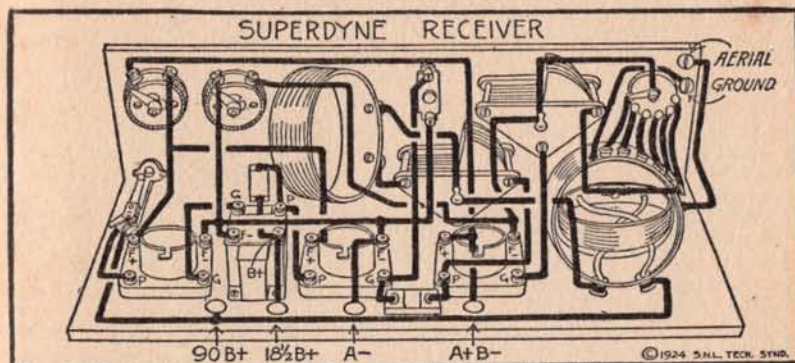

The Superdyne receiver shown above is an entirely new and efficient circuit using a stage of radio, detector, and a stage of audio frequency. It may be constructed with two stages of audio frequency if you desire.

The variocoupler is wound with 42 turns of number 22 double silk covered wire tapped at the 20th, 25th, 30th, and 35th turn. The antenna circuit consists of four turns of the same size wire wound on the outside of the 42 turn winding.

The rotor is wound with 36 turns of the same size wire. The separate coil shown consists of 46 turns of number 22 wire wound on a four inch tube. The variocoupler should be of the 180 degree type.

This circuit will not reradiate energy from the antenna, as energy from the plate of the radio frequency tube is fed back into the grid circuit in a reverse or "bucking" action that prevents the tubes from oscillating.

A Selective Tuned Impedance Circuit

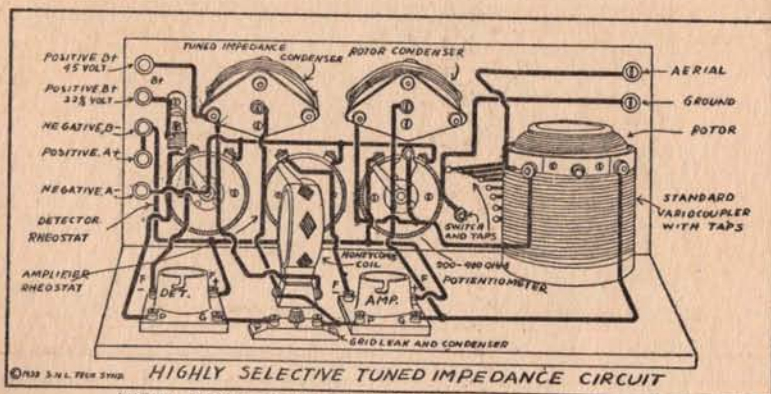

HIGHLY SELECTIVE TUNED IMPEDANCE CIRCUIT

VIEW FROM REAR OF PANEL

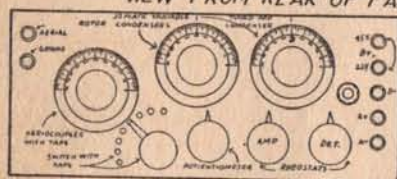

PANEL LAYOUT

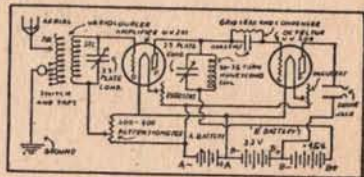

WIRING DIAGRAM

If you would like to try radio frequency amplification, the circuit given in this article describes a hookup from which very good results may be obtained. One stage of radio frequency is employed in connection with the detector, which will enable you to hear more distant stations than is possible with the detector alone. The circuit employs tuned impedance instead of a radio frequency transformer. This consists of a separate oscillating circuit, made up of a 30-turn honeycomb coil and a 23 plate condenser,

set up between the radio frequency tube and the detector, which greatly increases the volume of the incoming signal, before it reaches the detector.

An additional oscillating circuit is formed in the same manner by the secondary of the variocoupler and the twenty-three plate condenser across it, which is tapped off to the grid of the radio frequency amplifier tube. By this means the signal is increased in the rotor circuit, second, in the amplifying tube and, third, in the tuned impedance circuit.

A Non Reradiating Circuit

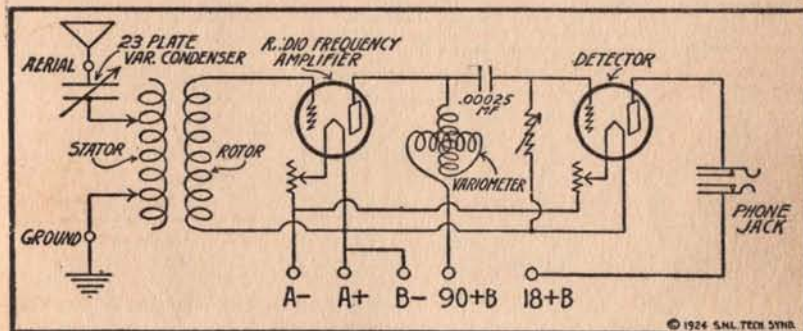
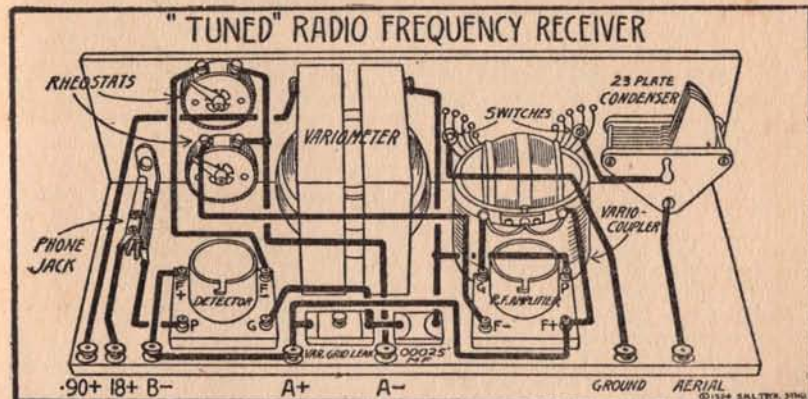

This is a circuit somewhat similar to the Tuned Impedance receiver shown on the opposite page. In place of the honeycomb coil and condenser a variometer is used to tune the circuit between the radio frequency tube and the detector.

This circuit has a number of good qualities. When properly operated it will not reradiate energy from the antenna. Distant stations, too weak to be heard on the detector alone, will be audible due to the stage of radio frequency amplifying the weak signal before it reaches the detector.

No potentiometer is shown with this circuit, the oscillations of the tube being controlled by the position of the variometer and the variocoupler dials. A separate rheostat is necessary for each tube as shown, due to the fact that the radio frequency tube must be burned a little brighter than the detector tube.

A double circuit jack is shown thus providing for the addition of two stages of audio frequency amplification without changing the equipment of the above pictured receiver.

How to Build a Two-Stage Radio Frequency Amplifier

A signal which is too weak to operate the detector tube cannot be amplified by audio frequency. To add more power to the receiver to enable it to tune in the weaker signals it will be necessary to amplify the incoming signals before they reach the detector tube.

Amplification of the incoming radio frequency currents before they reach the detector tube is accomplished by the use of additional vacuum tubes preceding the detector tube. This is possible due to the ability of the three element vacuum tube to amplify currents of any frequency. The incoming change of voltage impressed on the grid of the tube produces comparatively large changes in the plate circuit which accurately follow the changes in the grid circuit. In this manner the signal strength is increased by the amplifying characteristic of the tube, and the signal is brought up to a value which will make the detector function, after which audio frequency amplification may be employed to increase the volume. By the use of radio frequency amplification stations that were formerly inaudible can be brought in easily.

A distinct advantage of radio frequency over audio, is that incoming signals are amplified without the accompanying tube noises and other audio sounds, as currents of radio frequency only are handled by the transformer or coupling between tubes. This means that jarring the tubes will not disturb the receiver, and will not limit the number of stages that can be used as in the case of the audio amplifier. Due to the fact that the currents being handled by the radio frequency tubes are of an entirely different frequency than the audio currents there

is not the danger of coupling between the audio and radio frequency units that there is between several stages operating at nearly the same frequency.

The problem of adding stages of radio frequency to an already existing radio receiver consisting of a detector and one or two stages of audio frequency amplification is at first glance rather difficult. The majority of radio frequency hookups show apparatus in an entirely different arrangement from the ordinary regenerative receiver, and to follow the hookup would necessitate tearing the whole set down and rebuilding it. If your set is neatly assembled in a cabinet, or happens to be a manufactured article, you probably have not attempted radio frequency amplification for this reason.

The two-stage radio frequency amplifier described in this article can be very readily used with any standard receiving set including regenerative receiving sets. The amplifier can be built in a separate cabinet similar to that used in the construction of a two-stage audio frequency amplifier, and placed on the left side of the receiver.

In adding this amplifier to your receiver it is important to remove the wire from the antenna to the grid if you have a Reinartz, Ultra Audion, or any other form of direct feedback receiver. Also disconnect the wire that now connects the ground binding post of your receiver to either filament line.

Two radio frequency transformers of the socket mounting type are shown but any radio frequency transformer can be used. This type of transformer was used so that transformers could be changed for different wavelengths as easily as a

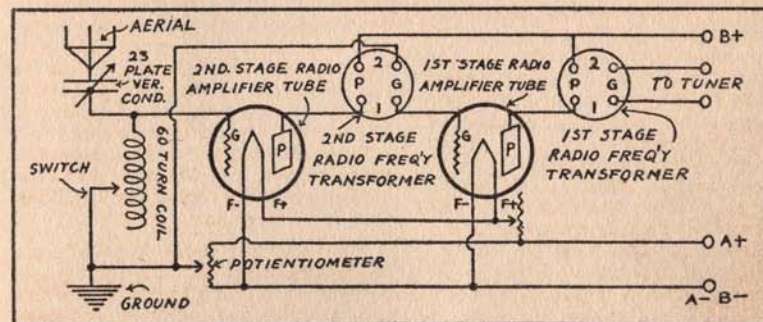
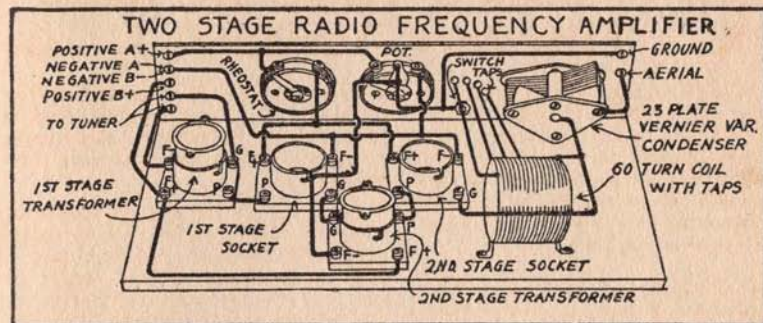

tube can be changed. The wiring diagram shows the connections direct on the transformers for those who prefer to use transformers of other design.

If you are going to use tubes that have a standard base such as the UV 201-A then four standard sockets will be necessary. If tubes that take a different type of socket are used than two standard sockets, and two sockets to suit the tubes will be required. One 200-400 ohm potentiometer, a 23-plate variable condenser, and a rheostat suitable for the tubes will be needed. A tapped coil consisting of sixty turns of number 20 wire wound on a 2½-inch tube, tapped at the thirtieth, fortieth, fiftieth, and last turns, is used. This requires a switch lever, four switch contacts, and two switch stops. A

variometer can be used in place of this tapped coil, and will provide somewhat smoother control of the inductance. Binding posts and wire complete the apparatus necessary to build the amplifier.

In radio frequency amplification it is important that all leads, and the plate and grid leads especially, be made as short and direct as possible to reduce the possibility of feedback between adjacent wires. A layout of the sockets to accomplish this result and a careful study of the picture diagram given before mounting the various articles and wiring them is strongly advised. You can arrange a combination that will make the plate and grid leads less than an inch apart. Loose wires and long leads should be avoided.

How to Build a One Step Audio Frequency Amplifier

METHOD OF ADDING TO SINGLE TUBE RECEIVER

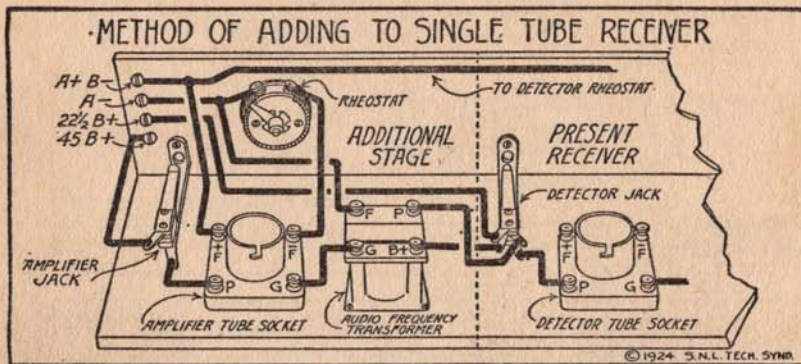

© 1924 S.N.L. TECH. SYND.

WIRING DIAGRAM

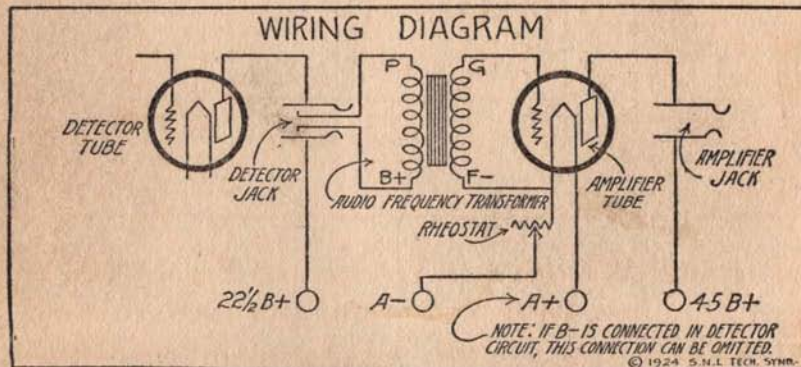

© 1924 S.N.L. TECH. SYND.

After you have constructed any of the one tube circuits shown on preceding pages, and you wish to add apparatus that will increase the volume of your receiver, the logical step to take is to add a stage of audio frequency amplification.

An additional tube, socket, and rheostat will be necessary. If you are using a single circuit jack in your detector stage at the present time purchase a two circuit jack to replace it with and use the single

circuit jack on the second stage.

An audio frequency transformer, an amplifier tube, and a 22½ volt B battery will also be necessary. Secure a tube that will use the same filament battery as your detector tube. For example: If you are using a UV 200 for a detector, secure a UV 201-A for the amplifier as both can be run from the same storage battery. Do not use a higher ratio transformer than a five to one if you desire quality of reproduction.

How to Build a Two-Step Amplifier

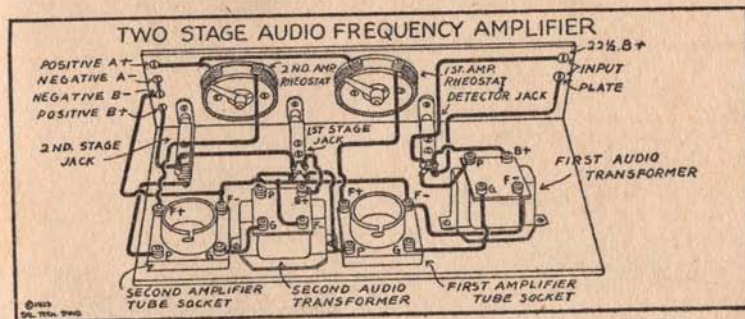

© 1924 S.N.L. TECH. SYND.

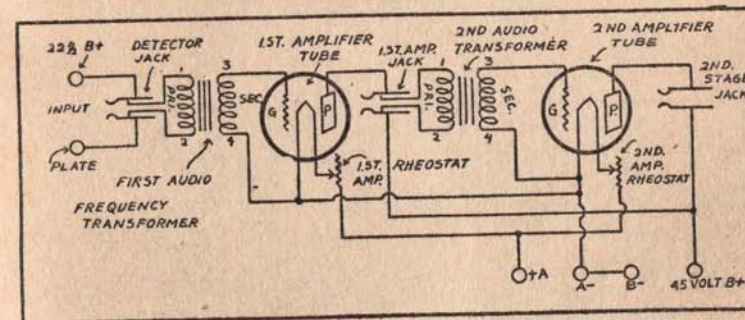

Use of Unit Will Increase Volume and Enable You to Use Loud Speaker on Your Set

There are a great many hookups for the construction of a tuning unit for radio reception. Nearly every hookup has its little peculiarities in the wiring construction which are more or less important. The two stage audio frequency amplifier, on the other hand, is standard, and is built alike for use with any hookup. The variations in construction of an audio amplifier are merely different methods of filament and output control. The telephones may be attached

to binding posts, or to a telephone plug and used with jacks, the hookup remains essentially the same.

The use of a two-stage audio frequency amplifier will enable you to increase the volume of sound so that a number of headphones or a loud speaker can be used. Distant stations that were too faint to be enjoyed on the detector tube alone, can be brought in quite clearly with the use of amplification.

The Push-Pull Amplifier

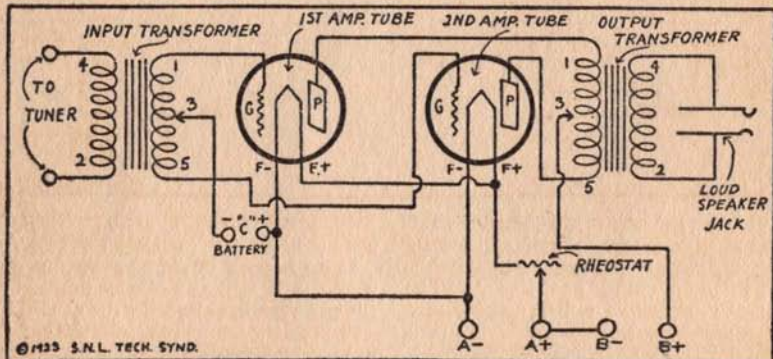
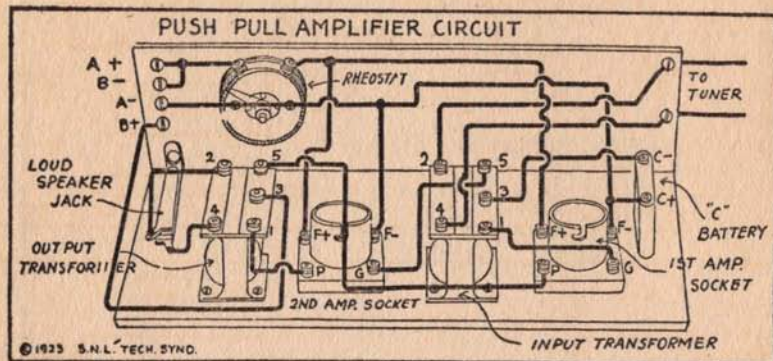

This is an amplifier for use in conjunction with any type of receiving set. It can be attached to a regular detector and two-stage receiver for the purpose of amplifying the signals for loud speaker reception without adding distortion to the output.

Special transformers having a tap taken off from the center of the windings, must be used for this circuit. One "Input" and one "Output" transformer will be required.

With this arrangement B battery voltages up to 150 volts may be used, together with a C battery of from three to nine volts, without causing distortion.

As the tubes are connected in parallel it is possible to remove one of the tubes from the socket of the amplifier without causing the amplifier to cease working. Be sure to use two tubes of like characteristics, i. e., two UV 201-A tubes.

Wave Traps to Tune Out Interference

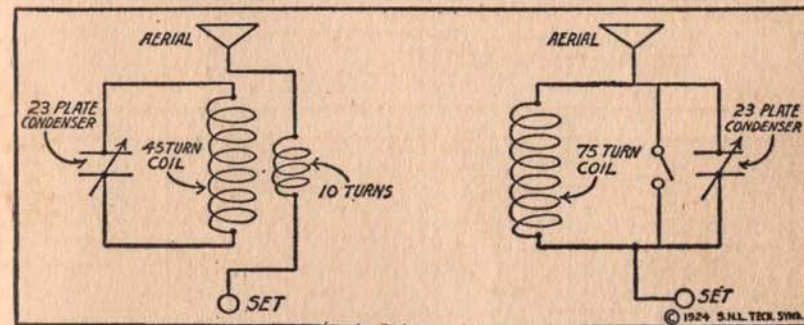
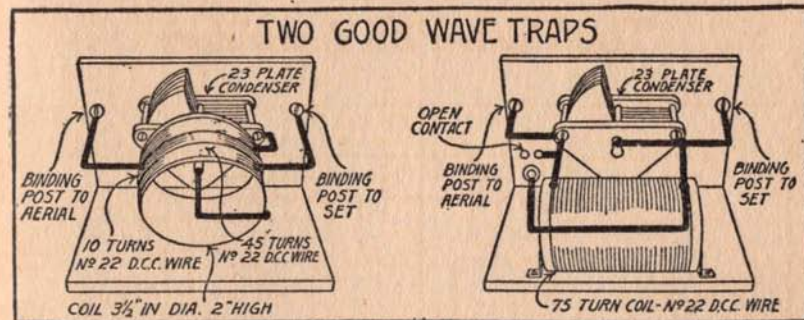

If you are suffering from considerable interference from a nearby station, either code or broadcasting, a wavetrapp will enable you to tune out the offending station and listen to other programs.

The filter shown on the left side is built on the absorption principle, having two coils. One coil consists of forty-five turns of number 22 cotton covered wire wound on a $3\frac{1}{2}$ inch tube.

The ends of this coil are connected to the two connections on the 23 plate variable condenser.

On top of the 45 turn winding is wound ten turns of the same size wire, one end being connected to each binding post. This coil is not

connected directly to the 45 turn coil but works by induction.

The second filter, the one on the right side, is easier to construct as it has only one winding on it. This consists of 75 turns of number 22 double covered magnet wire wound in a single layer.

The two ends of this coil are connected to the two binding posts and to the two sides of the 23 plate variable condenser.

An additional feature is added, namely that of a shorting switch placed across the two binding posts.

This permits the shorting out of the wavetrapp when it is not required, a valuable feature as the filter introduces some losses into the antenna circuit.

RADIO SYMBOLS AND THEIR MEANING					
	AERIAL			AUDIO FREQUENCY TRANSFORMER	
	GROUND			RADIO FREQUENCY TRANSFORMER	
	BATTERY			JACK	
	CONDENSER (FIXED)			COIL	
	CONDENSER (VARIABLE)			POTENTIOMETER	
	GRID LEAK (FIXED)			TUBE SOCKET	
	GRID LEAK (VARIABLE)			FILAMENT SWITCH	
	VARIOMETER			NO CONNECTION	
	VARIO-COUPLER			SOLDERED CONNECTION	
	RHEOSTAT			CRYSTAL	

© 1924 S.N.L. TECH. SYND.

How to Select the Parts for Your Set

Good Hook-up Is Ruined by Poor Material

The radio industry is but in its infancy. The entry of popular broadcasting into the radio game created such a demand for parts and sets that the existing manufacturers were wholly unable to supply the demand, and a great number of new manufacturers commenced to make radio parts. The result was that a great mass of poor quality radio apparatus made by dishonest manufacturers was placed on the market. A certain class of manufacturers were honest enough, but lacking in experience and knowledge of the fundamentals required for the manufacture of first class radio apparatus.

The unscrupulous manufacturers do not hesitate to copy some well established product detail for detail down to the last nut, using raw materials of inferior quality, and market it under a trade name similar to the well known product. Unless you are familiar with the real article you will have difficulty in distinguishing between the two when purchasing material for your radio set. The result of using materials of this kind cannot be anything other than a poor working receiver. Buy apparatus made by a manufacturer who has made good and whose apparatus is handled by legitimate dealers.

On the other hand there are a great many manufacturers who are absolutely honest and painstaking to see that nothing but first class

apparatus bears their trademark. These men spend many thousands of dollars in experimental work before bringing new apparatus on the market with the assurance that their work will be recognized and appreciated by the buying public.

Radio products are not standardized to a point at this time however that we can go into a radio supply house and buy a rheostat or a condenser the same as we would buy a package of safety razor blades with the assurance that we will receive a standard product of first quality. It is important that we know the good and bad points of the design, and of the materials used when buying radio apparatus.

The use of good materials in your radio set cannot be over emphasized. There are enough uncertainties about entering on the construction of a radio set that you cannot afford the expense of investing money in poorly built and inefficient parts. If the set does not operate as it should after construction you will be at a loss as to whether the circuit, your workmanship, or the material you have used is the source of the trouble. Too often the circuit is blamed for poor functioning of the set which is directly traceable to poor material. If it does work there is always the question as to whether it would not work better if a first class socket or condenser were used instead of the poor quality one you have at present.

How to Select the Condensers

Poor Part May Ruin Good Set By Too Great Resistance

The received energy in a radio receiving set is so small that losses cannot be well afforded. A poor condenser in the circuit may introduce a resistance greater than the rest of the set combined with the antenna and ground resistance. For this reason you should use only the very best of condensers when building your radio receiver.

There are a great many makes of variable air condensers on the market, all seeming to be built along the same lines, so that a casual inspection without knowing the weak points to look for will be of little value.

Good workmanship is the first point to look for. A manufacturer who will put out a product of inferior workmanship will probably use inferior material. This may mean a saving for you of a dollar or two at first but more expensive in the end as the condenser will probably have to be removed to be replaced with a good article later in order to derive satisfaction from your set.

The condenser plates must be true and level, and the washers or spacers used in the separation of the plates be uniform to a high degree of accuracy. The degree of separation between the rotor and stator plates is so small that if the best of materials and workmanship are not used the plates may warp so that the plates touch and produce a short circuit. Examine the condenser to be sure that the shaft runs true and that the plates interleave without touching each other.

Run your finger lightly over the edge of the plates before buying a variable condenser. If you can detect burrs left by the cutting dies

the condenser is not first class. The burrs are ragged edges which allow the static charges of the condenser to leak across and many losses can be traced to them.

The different makes of condensers vary greatly as to the quality of the insulating material used for the bushings, and insulated supports which insulate the stationary plates from the moving plates. Fibre has a comparatively low dielectric strength for insulating purposes and has the disadvantage of absorbing moisture. Hard rubber and insulate are nearly as bad. Poor quality of insulation such as when the above insulating compounds are used, are the source of considerable electrical losses in the cheap type of condensers being turned out in large quantities today. This is due to leakage through the insulating material or to the absorption effect of the material with respect to electrostatic charges, or a combination of both.

Bakelite, formica or some other good insulating material should always be used in the construction of the end plates and bushings. If the material will soften under heat, or scrape easily with a knife the condenser is likely to have a low point of efficiency.

The plates should turn easily yet have an adjusting spring on the shaft so that the tension on the shaft can be adjusted so that the rotor will "stay put" when the hand is removed. If a vernier condenser the main shaft should turn without turning the vernier shaft and vice versa. To insure long life and easy working of the shaft it is important that the condenser be fitted with brass bearings.

How to Select a Variocoupler

There are a number of points to check when you are buying a variocoupler. In general you should always examine the workmanship to be sure that you are getting a first class product. Examine the windings on both the stator and rotor to see that the wire is tight and not liable to loosen with use. Note the manner in which the taps are taken off on the primary or stator winding. The taps should be taken off in such a manner that they can be soldered to readily without loosening the turn of wire they are connected to.

The bearings through which the rotor shaft runs should be next examined. As in the case of the variometer the connection from the rotor to the binding posts on the stator are often made through the contact of the shaft on the bearing. If a good wiping contact is not obtainable the variocoupler will not work satisfactorily. Many variocouplers are provided with pigtail connections between the rotor circuit and the external connections for this reason. A more positive connection will be assured with pigtail connectors, yet the wire used must be of the best grade of flexible wire or the constant bending and twisting they are subjected to in use will soon break the connection. A stop should be incorporated on the rotor shaft of every variocoupler which uses pigtail connectors to prevent turning the rotor too many times in one direction of rotation and thus causing the wire to be twisted and broken.

The majority of cases of trouble with variocouplers is caused by the

turning of the shaft when the rotor is binding or caught. This will break the wire on the inside of the rotor which makes the connection from one end of the rotor winding to the shaft. This makes an open connection that is troublesome to find on account of being located in an out of the way spot. Examine the shaft to make sure that it is fastened tightly to the rotor proper and is well soldered to the end of the rotor winding.

Variocouplers are provided with taps on the primary inductance or stator for changing the value of the primary winding. One end of the coil is tapped at every turn and the other end is tapped at intervals. This arrangement will permit you to use two sets of switch levers and contacts. One set will vary the inductance in large steps, the other will permit you to vary the inductance between the large steps so that the primary inductance can be tuned to within a part of one turn of the most efficient amount of inductance required.

When the variocoupler is used in the two circuit tuner it provides the transformer by which the incoming signals are transferred from the aerial circuit to the secondary circuit. When the variocoupler is used in the "Variocoupler Feedback" receiving set the stator is used for the primary inductance of the set and the secondary is connected in the plate circuit for a tickler coil. When used for the latter purpose the variocoupler forms the entire inductance used in the circuit.

How to Select the Variometer

Tight Windings, Good Connections, and If of Wood, Well Seasoned Materials Are Required

One of the most important things to look for when buying a variometer is the manner in which the connection is made between the rotor or movable part and the stator or outside stationary windings. In a good many variometers this connection is made by contact of the rotor shaft with the metal bearings at the ends of the variometer. One end of the stator winding is connected to the bearing and one end of the rotor winding is connected to the shaft. As a connection is always made between the shaft and the bearing, the circuit is complete no matter what position the rotor is placed. Due to wear of the bearing, or corrosion of the metal, this method of contact is not always positive. The best form of connection between the rotor and the stator is made by the "pigtail" method. The pigtail connection is made by soldering a flexible wire between the rotor shaft and the bearing. If this method is used a stop should be located on the variometer shaft so that the rotor cannot be turned more than one revolution in one direction, which might result in twisting off the pigtail connection.

In your selection make sure that the windings are tight. If they are loose then later on they may rub on each other which will wear out the insulation on the wires so that some of the inductance may be shorted out at times. If a wooden variometer is preferred be sure that it is made out of well seasoned wood that will not warp out of shape later on. The best wooden variometers are made from seasoned hard maple.

Probably the best variometers are, however, made from moulded bakelite.

The variometer consists of two coils of wire, one of which is wound on a stationary form or tube and the other is wound on a smaller tube or a ball form which rotates inside the fixed coil. The stationary and the movable coils are connected together in series, one external connection of the variometer being made onto the free end of the rotor winding and the other connection on the free end of the stationary winding.

The number of turns on the coils remains fixed, the variation of inductance being accomplished by rotating one coil inside the other so that their relative positions are altered. When the windings of the two coils are in a parallel position and are connected so that the current flows in the same direction, the lines of force from the two coils flow in the same direction, and the coils have practically no effect on each other. In this position the inductance of the variometer is at a maximum. When the inner coil or rotor is in any other position the lines of force do not act in unison and the value of the inductance is decreased. When the rotor is parallel with the windings on the stator but the wires are running in opposite directions, then the lines of force are opposing each other and the value of the inductance will be nearly zero, providing that each winding has an equal number of turns.

How to Select Vacuum Tube Sockets

When you are choosing vacuum tube sockets examine the contacts carefully to see that a wiping contact will be made with the vacuum tube contacts. Pluck the contacts to see if they are of strong springy material that will come back into shape after being bent. If they are not of phosphor bronze, but of some soft inferior material they will bend easily when a tube is inserted in the socket and STAY BENT. This will mean that an uncertain contact will be made with the tube and you will have to bend the contacts up often to assure a connection. If the sockets are of the moulded variety be sure that they are made of material that will not break easily.

Almost any socket will work but too much importance cannot be attached to the selection of this article. A poor socket may cause you no end of trouble and your set will work much better if a first class socket is used.

Various articles used in the construction of a radio set are being moulded of insulating material. The foremost material used is bakelite. This substance has a very high insulation test and is very good for radio work. Bakelite is not affected by heat or moisture to any great extent. There are a number of substitutes being used that are very poor in insulation qualities, and have other disadvantages, yet are used a great deal in cheaper articles. The use of these substitutes will greatly decrease the chances of your set functioning at its best.

The currents in a radio circuit are of very high frequency and will creep over or leak through insulating materials that are perfectly satisfactory for ordinary commercial electrical use. In the base of some sockets on the market fibre is used. Fibre does not measure up to the standards of high insulation strength required for radio use. It has the added disadvantage of absorbing moisture making it absolutely unfit for first class work.

In a good many inferior sockets the insulating material is of "moulded mud" as a good many experimenters have named it. This material is to be avoided wherever possible. It contains a large percentage of carbon coloring matter which makes it very low in insulating value so that you cannot expect any kind of efficiency with its use. From outside appearances this material looks good but it can be easily distinguished from bakelite because it is soft and easily cut with a knife.

Any insulating material that will soften under heat should not be used under any circumstances. Any attempts to solder to binding posts in this material will result in the metal parts changing their positions and thereby often open-circuiting some important connection. This open circuit will be very hard to find and difficult to repair when found. Test the material by holding one corner of it for an instant in the flame of a lighted match. If it starts to soften or burn do not use it in your set.

How to Select and Operate Rheostats

When you buy a piece of radio apparatus it is not often that you will be able to actually test it out before purchasing. It is for this reason that you should make a very careful examination to avoid disappointment in the purchase of radio parts.

In the selection of rheostats there are a number of points to be considered. The contact arm should fasten securely onto the shaft by means of a set screw. The end of the contact arm that makes contact with the resistance wire should be bent up in such a manner that it will slide freely over the top of the wires, making contact at all points. Examine the wire on the rheostat. If it is so loose that you can move it with the fingers, you will be likely to have some short-circuited turns after a short time in use. The strip upon which the resistance wire is wound, as well as the base of the rheostat itself, should be of material that will not soften under heat. If the rheostat knob is screwed onto the threaded end of the shaft you will undoubtedly have considerable annoyance with the rheostat knob coming loose instead of turning the contact arm.

How to Use the Rheostats

A safe rule to follow in the operation of vacuum tubes is to burn the filament as low as possible consistent with results. Some operators,

through ignorance, do not use the resistance in their rheostats except to turn the filament current on and off, and when operating their set the filament rheostats are turned fully on, cutting all the resistance out of the filament circuit and throwing the tubes directly across the line. This procedure shortens the life of the tube a great deal and also cuts down the volume of the output.

The tungsten filament tubes such as the UV 200, UV 201, C 300, and C 301 appear to be burning brightly even though the amount of current flowing through the filament is not sufficient to heat the filament of the tube to the point of maximum electron emission. The tubes will appear to be brightly lit when placed on a four volt storage battery, however, the results will be very faint signals in the phones or none at all.

With an ordinary six-volt storage battery there is little danger of burning out the filament of the tubes if the rheostat is all cut out for a few minutes. Tune in on a station and cut out all the resistance in your rheostat gradually to see if better results are secured with your rheostat turned up higher than you are accustomed to turn it. A safe rule to follow when using the above named tubes is to turn up your rheostat until a hiss is heard. Then turn the rheostat down until this just disappears and you have found the operating point for the tube.

Select a Good Grid Leak

Its Action Important in Set

A grid leak and condenser is standard equipment on nearly every Radio receiving set in use today. There is probably no other single piece of apparatus used that is so small and insignificant in appearance as the grid leak, yet it is one of the most important, and its action can either make or mar the most expensive receiving set.

The majority of ills that can affect a radio receiving set can be cured by the proper adjustment of the grid leak, or by the use of a grid leak in the proper place in the receiving circuit. The grid leak must be adjusted for the particular tube and circuit that it is being used in, if the greatest efficiency is to be obtained. This adjustment must be made while the receiver is being used and the set tuned in to an incoming signal. The grid leak gives stability to the tube circuit, prevents paralyzing of the tube, and often increases the signal volume and audibility several times.

The grid leak, when properly adjusted, will often increase signal volume and audibility several times. An explanation of the action of the grid leak in the circuit is necessary for you to fully understand the importance of this.

The action of the grid leak must be explained in connection with the action of a vacuum tube. The tube filament when heated gives off a

stream of negatively charged electrons. The plate of the tube is charged positively by the B battery. Unlike charges attract and like charges repel so the negatively charged electrons are drawn over to the positively charged plate from the negatively charged filament.

There is a mesh of wire between the filament and plate through which the electrons must flow, and this is called the grid. The incoming signals go directly to the grid, and as they are positive they cause the grid to become positive. The grid being between the filament and plate and being positive adds further inducement to the electrons to leave the neighborhood of the filament and flow to the plate. When the grid is negative this places a barrier between the filament and plate and practically stops the flow of electrons, and consequently the signals in the phones.

The resistance of the grid leak must be neither too high nor too low if it is to function properly in the circuit. The resistance in the grid leak enables the negative charges to leak off the grid circuit and allow it to become positive when an incoming signal is impressed on it, and thus keeps the tube from "blocking." This does not interfere with the incoming signals as they are of radio frequency which is very high and will take the easier path through the grid condenser.

How to Use the Potentiometer

The potentiometer is an instrument by which variation in voltage between the taps can be secured. The potentiometer is, in fact, a high resistance rheostat which is used to control small amounts of high voltage current. The most familiar form of potentiometer is the so-called "A" battery potentiometer which has a resistance of from 200 to 400 ohms. This may be a resistance wire wound in the form of a rheostat, provided with a contact arm, or it may be in the form of a carbon rod or flat circular disc provided with a slider on it. In either case connections are made on both ends and on the slider arm making three connections. The center terminal, the one that is connected to the contact arm, should be connected to negative B battery. The two outside connections should be connected one to negative A and the other to positive A battery.

In adjusting the B battery voltage on the detector tube to secure maximum results you may find that there is no appreciable difference between two adjacent taps. This indicates that the correct voltage lies somewhere in between the two taps. The results from your set will improve greatly if this point can be reached and used.

The potentiometer should always be connected across the A battery and NEVER across the B battery as it will run the battery down in a short time. When it is used across the A battery the small amount of current used, approximately fifteen thousandths of an ampere, is negligible. When used across the B battery the

current consumed would be about five or six times that amount which will run down your B battery in a very short time, and often will burn out the potentiometer.

The potentiometer is a vernier control on the B battery voltage to all tubes, if your B battery is connected in series having but one negative terminal and that leading to the center connection on the potentiometer. This variation in plate voltage produces noticeable effects on the detector tube.

On local stations it does not seem to affect the tuning if the potentiometer is turned full on in one direction or the other. Neither will the vernier rheostat or the vernier condenser adjustment produce any very noticeable changes when used on local signals.

The proper method of tuning with a potentiometer is as follows: Turn your detector rheostat on until the tube is just below the oscillation point where the music or speech becomes distorted or "mushy." The potentiometer should be turned to a point halfway between the two terminals and the rheostat advanced to a point where the tube can be made to oscillate by turning the potentiometer on further in one direction or the other. When the signal is tuned in, advance the potentiometer as far as you can without causing the tube to start oscillating. This is the proper point to receive signals. When you become accustomed to this instrument it will prove to be the favorite method of tuning in distant stations due to its fine adjustment qualities.

How to Select the Batteries

B batteries are one of the few things about a radio set that will wear out and need replacement from time to time. The best B batteries only have a shelf life of about six months, so if your set does not function as good as it did at first, the chances are that your B batteries are becoming exhausted.

Due to the comparatively short life of B batteries, insist on seeing the date of manufacture on the next B batteries you buy so that you do not pay full price for an article which is half dead. Do not accept batteries which have a date on them over two months old. Also refuse to accept batteries which have bumps or bulges in the sealing wax cover caused by gassing of the cells. Batteries with this fault do not as a rule have a very long life. Some of the cells dry out and become dead making the whole battery have a higher resistance and become noisy.

In buying your B batteries take no chances with an unknown battery although it may be a little cheaper. Buy the product of a well known manufacturer who has passed through the experimental stage. The improved reception of your set will more than make up any difference in price.

Batteries for the plate supply of a radio set are made in two common sizes, the 22½ volt size and the 45 volt size. The 45 volt size is used a great deal on account of its form

being convenient for the average set containing a detector and two stages of audio frequency amplification. The 45 volt units are more convenient when a high voltage is desired for the operation of a power amplifier.

The difference between success and failure of a radio receiving set lies in the adjustment of the "B" battery of the detector tube. The amount of plate or "B" battery voltage impressed on the different tubes must be correct for the tubes used or full efficiency will not be obtained.

A tapped 22½ volt "B" battery should be used on the detector tube. The method of finding the proper plate voltage to use on a detector tube is to tune in on a distant or weak signal, then vary the positive "B" battery lead from tap to tap on the "B" battery until the loudest signal is secured. This is the proper operating voltage for this tube, and the connection should be left at this point as long as that particular tube is used. When the "B" battery becomes older and the voltage drops, the lead may be moved to the next higher tap to secure the correct operating voltage. If another tube is used for a detector, the proper operating voltage may differ, and it is best to vary the voltage until the proper tap is again found for the new tube.

How Single Circuit, Two-Circuit, and Three-Circuit Receivers Are Operated and Tuned

The Single Circuit Receiver

You have probably been puzzled and confused by the different kinds of radio circuits being written and talked about. Without going into technical engineering details I will give a short explanation of the single circuit type.

The single circuit tuner was the first type to be used extensively. For a time it was pushed into the discard but has lately returned to popular favor and now is probably used more extensively than any other type. Briefly it consists of a single inductance for tuning, and the whole set, mechanically, is of one circuit. That means that you can trace the wiring from the aerial to the headphones without going across open spaces or breaks in the circuit other than batteries and condensers. Many of the manufactured receiving sets today are of the single circuit type.

The single circuit tuner makes use of a coil of inductance which has one end connected to the aerial and the other to the ground. This in-

ductance is varied by slide contacts, taps, or by a variable inductance such as a variometer, or a combination of these methods. The receiver is tuned to the wavelength of the incoming high frequency currents by varying this inductance. The tuning of the continuous wave broadcasting stations is very sharp so that it is often difficult to tune the station in exactly by means of taps alone and a variable condenser is used in the antenna circuit. The addition of a variable condenser provides a means of continuous variation of the inductance and enables the receiver to tune to lower wavelengths.

The present popularity of the single circuit lies in the fact that it is the easiest of the several circuits to tune. The adjustment of the primary inductance is the only thing necessary to change the tuning of the set, and this is usually accomplished by the use of a single control, the variometer dial or the antenna condenser dial.

The Two-Circuit Receiver

In place of the single inductance coil or variometer used for the primary inductance in the single circuit tuner two inductance coils may be used, in which case the receiver is placed in the two-circuit class. A common form of inductance used is the receiving transformer, commonly called a "loose coupler," in which the primary and secondary consist of turns of wire wound on insulated tubes. The secondary slides inside the primary coil for varying the coupling between the two coils. Both the primary and secondary are tuned by taps brought out from the windings.

The variocoupler forms another popular inductance for the two circuit tuner. The primary winding is usually on an insulated tube varied by taps, and the secondary is wound on a ball which is rotated with respect to the primary, and can be tuned by a variable condenser connected across the coil.

In the two-circuit tuner the primary inductance is connected between the aerial and ground. The secondary inductance is then connected to the remainder of the set in the same manner as the inductance in the single circuit. The incoming radio frequency impulses are transferred from the primary inductance to the secondary inductance by the process of induction, there being no direct connection to the detector tube from the aerial as in the case of the single circuit tuner.

The primary circuit is tuned approximately to the wavelength of the station to be received and the secondary coil is tuned in resonance

with the primary. This permits greater selection in tuning and will enable you to tune one station in and eliminate other stations as well as the greater percentage of code interference which may be present.

Advantage of Two-Circuit Set

The two-circuit receiver has two or three tuning controls in contrast with one control with the single circuit tuner. These are: the primary inductance control, the secondary inductance control, and the coupling control between the inductances. This makes tuning a little more difficult at first but is more than recompensed for by the greater selectivity of the two-circuit tuner.

When first tuning in a station it is best to have the coupling control at its maximum setting and the primary inductance about half way. Now tune carefully over the scale with the secondary inductance control. If no signals are heard change the setting of the primary and again carefully tune with the secondary control. When a signal is heard turn the primary inductance dial slightly and retune with the secondary dial.

When the loudest results are secured in this manner the coupling dial should be turned back slightly and the primary and secondary controls readjusted in order to secure a louder signal. You will find that the further the coupling dial can be turned in the minimum direction the greater the selectivity or ability of the set to tune out undesirable signals will be, and it is usually possible to tune out all but powerful local stations in this manner.

The Three-Circuit Receiver

The two circuit tuner is changed into a three circuit tuner when an inductance coil is placed in the plate circuit. This inductance, often called the "feedback" or "tickler" coil, does not constitute a separate circuit although it is called one.

The plate circuit is that part of the hookup between the socket binding post of the detector tube marked "P" and the telephone binding post or jack. The insertion of a coil of inductance in the plate circuit causes a transfer or feedback of energy from the output of the detector tube back to the input circuit of the tube. The energy that is thus transferred is again passed through the tube and amplified, resulting in a greatly increased signal strength as compared with the two circuit non-regenerative set.

A fixed tickler is not used to any great extent due to the fact that this inductance must be tuned for each change in tuning of the primary and secondary circuits. A greater amount of tickler must be used as the inductance of the tuning circuit is increased. For this reason the tickler usually consists in whole or in part of a continuously variable inductance such as a variometer.

The relation of the tickler coil to the primary and secondary inductance is a matter which you will probably determine by experiment. If the tickler coil is placed too close to the other inductances in the set, or has too many turns, then too much energy will be transferred back to the grid cir-

cuit. This will cause the set to oscillate and signals will be distorted. If too few turns are used on the tickler, or it is placed in non-inductive relation with the primary inductance then it will be impossible to bring the set into an oscillatory state, just below which is the proper place to receive signals.

The chief complaint against the single circuit tuner is that it is too broad in tuning and is not selective enough. One broadcasting station is all that is desired at one time, and that without interference from code transmitting stations. The three-circuit tuner has the advantage of being able to select the station to be received without so much interference from other stations, but this advantage is gained at the sacrifice of simplicity of tuning.

When tuning, place the plate variometer or tickler coil at minimum and tune the primary circuits in the same manner as for the two-circuit tuner. When a station has been tuned in with the primary and secondary inductance controls, advance the tickler until the volume is satisfactory or the tube commences to oscillate. The reception while the tube is oscillating will not be good on account of the muffled quality of the music or speech. The proper reception point is that just below the oscillation point. This may be reached by turning back the tickler adjustment or the detector rheostat slightly until the tube ceases to oscillate, and then turning either control on again to the point just before the tube will again oscillate.

YOU WILL ALWAYS
FIND SOMETHING
INTERESTING
IN THE
ENQUIRER

SPORTS

POLITICS

SOCIETY

THE DRAMA

DRESS AND

HOUSEHOLD HINTS

ARE ONLY A FEW OF THE DEPARTMENTS OF THIS GREAT NEWSPAPER